

**Lawn tractor  
Rasentraktor  
Tondeuse autoportée**

# **LawnBoss**

## **6018-H**

---



---

**GB Spare Part List**  
**D Ersatzteilliste**  
**F Liste de pièces détachées**

**2004**



# Contents - Inhalt - Index

Page - Seite

---

<b>1 Engine</b>	<b>Motor</b>	<b>Moteur</b>	<b>.....2</b>
<b>2 Front axle</b>	<b>Vorderachse</b>	<b>Essieu avant</b>	<b>.....4</b>
<b>3 Steering</b>	<b>Lenkung</b>	<b>Direction</b>	<b>.....6</b>
<b>4 Main frame</b>	<b>Rahmen</b>	<b>Chassis</b>	<b>.....8</b>
<b>5 Hydrostat pedals</b>	<b>Getriebe Pedale</b>	<b>Pompe Pédales</b>	<b>.....10</b>
<b>6 Hight adjustment</b>	<b>Mähwerk-Höheneinstellung</b>	<b>Hauteur de coupe</b>	<b>.....12</b>
<b>7 Cutting pan assy</b>	<b>Mähwerk</b>	<b>Tondeuse</b>	<b>...14-16</b>
<b>9 Tunnel-Catcher sup.</b>	<b>Tunnel-Hinterplatte</b>	<b>Tunnel-support bac</b>	<b>.....18</b>
<b>10 Grass catcher</b>	<b>Grasfangkorb</b>	<b>Bac récolteur</b>	<b>.....20</b>
<b>11 Dash board</b>	<b>Armaturenbrett</b>	<b>Tableau de bord</b>	<b>.....22</b>
<b>12 Seat assy</b>	<b>Sitz</b>	<b>Siège</b>	<b>.....24</b>
<b>13 Body</b>	<b>Aufbauten</b>	<b>Carrosserie</b>	<b>.....26</b>
<b>14 Electrical system</b>	<b>Elektro-Kabelbaum</b>	<b>Installation électrique</b>	<b>.....28</b>
<b>15 Labels</b>	<b>Aufkleber</b>	<b>Etiquettes</b>	<b>.....32</b>

---

**ENGINE  
MOTOR  
MOTEUR**

1

2004

Nr.	REF.	DESCRIPTION	BEZEICHNUNG	DESIGNATION	QTY
1	947482349009	Engine Intek 18 HP	Motor Intek 18 HP	Moteur Intek 18 HP	1
2	532927262043	Extension	Ansatz	Allonge	1
4	532085415543	Cover	Leitblech	Deflécteur	1
5	947309203504	Hex screw M 8x20	Sechskantschraube M 8x20	Vis hex M 8x20	2
5.1	947311214502	Washer 8	Scheibe 8	Rondelle 8	2
5.2	947311210503	Falt washer 8.4	Scheibe 8.4	Rondelle 8.4	2
7	532927472263	Exhaust system	Auspufftopf	Échappement	1
8	947309203530	Hex screw M 8x35	Sechskantschraube M 8x35	Vis hex M 8x35	4
8.1	947311214502	Washer 8	Scheibe 8	Rondelle 8	4
8.2	947311120502	Nut M 8	Sechskantmutter M 8	Ecrou M 8	4
9	532092312133	Square	Passfender	Clavette	1
10	947532150439	Engine pulley	Keilriemenscheibe	Poulie à gorge	1
11	947311122501	Rubber boot W 1/4"-20 UNC zinc	Isolator W 1/4"-20 UNC zinc	Ecrou W 1/4"-20 UNC zinc	1
12	947443900085	Throttle lever assy 9-8071-223	Gasverstellhebel 9-8071-223	Levier d'accélérat. 9-8071-223	1
12.1	947443900093	Throttle lever assy GAR 00	Gasverstellhebel 0-8060-238	Commande de gaz 0-8060-238	1
12.2	947309231505	Screw M 4x10 cyl.head-slotted	Schraube M 4x10	Vis M 4x10	1
12.3	947311129514	Self locking nut M 4	Sichermutter M 4	Ecrou M 4	1
13	532080302873	Bracket	Aussteifung	Entretoise	1
13.1	947309251514	Screw M 5x14	Schraube M 5x14	Vis M 5x14	4
13.2	947311129515	Locking nut M 5	Mutter M 5	Ecrou M 5	4
14	947443612011	Choke MK01 9-8074-277	Startvergasser MK01 9-8074-277	Choke MK01 9-8074-277	1
18	532027662043	Fuel tank 0-2766-204	Tank 0-2766-204	Reservoir 0-2766-204	1
19	947321841017	Fuel tank cap	Tankverschluss	Bouchon	1
20	947000532058	Fuel line clamp UM 5008	Schlauchshelle UM 5008	Collier UM 5008	1
21	532199202323	Fuel line	Kraftstoffschlauch	Durite essence	1

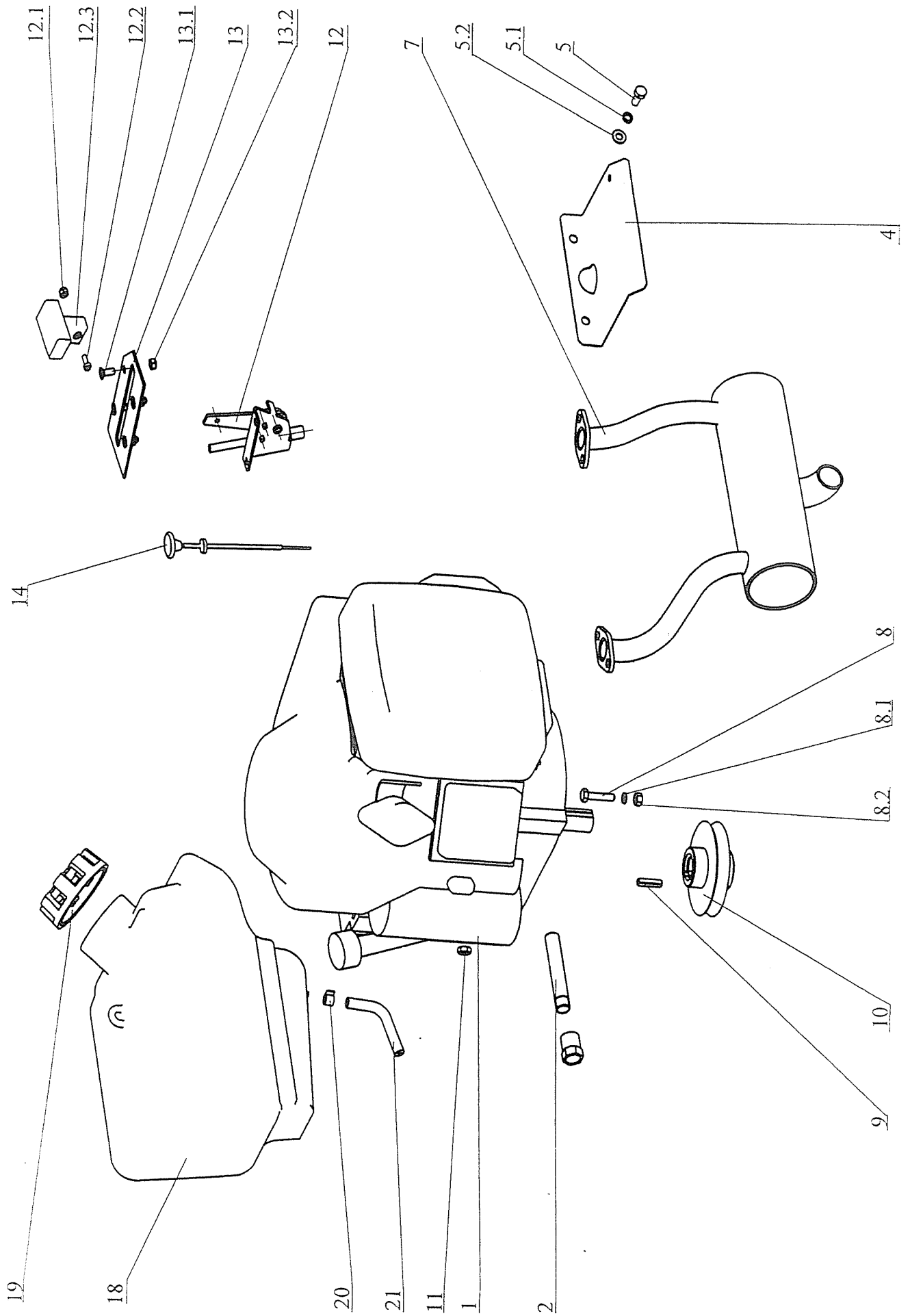

**FRONT AXLE  
VORDERACHSE  
ESSIEU AVANT**

**2**

**2004**

Nr.	REF.	DESCRIPTION	BEZEICHNUNG	DESIGNATION	QTY
1	532916432153	Spindle R	Achsschenkel R	Fuseé D	1
2	532016542063	Front axle	Frontachse	Essieu av.	1
3	947442073020	Angular joint 16P DIN71802CSM1	Kugelgelenk 16P DIN71802 CS M	Cercle angulaire 16P DIN71802	1
3.1	947311129521	Nut M12 Tensilok BN190KL	Mutter M12 Tensilok BN190KL	Ecrou M12 Tensilok BN190KL	2
4	947532980126	Tie rod 0-9010-555	Spurstange 0-9010-555	Tige filetee 0-9010-555	1
4.1	947311120504	Hex nut M 12	Sechskantmutter M 12	Ecrou hex M 12	1
5	947442073019	Angular joint 16L DIN71802CSM1	Kugelgelenk 16L DIN 71802CS M1	Cercle angulaire 16L DIN71802	1
5.1	947311120539	Nut M12 L	Mutter M12 L	Ecrou M12 G	1
6	532080503603	Lever	Hebel	Levier	1
6.1	947309203524	Hex screw M 6x40	Sechskantschraube M 6x40	Vis hex M 6x40	1
6.2	947311129513	Self locking nut M 6	Sichermutter M 6	Ecrou M 6	1
7	947311728003	Square key 5x7.5	Scheibenfeder 5x7.5	Clavette 5x7.5	1
8	947311732008	Spring clip "C" 15	Sicherscheibe 15	Clips 15	2
9	947311210514	Flat washer 19	Scheibe 19	Rondelle 19	4
10	947425111004	Grease fitting MK 6x1	Schmiernippel MK 6x1	Graisseur MK 6x1	2
11	532016432143	Spindle L	Achsschenkel L	Fuseé G	1
12	532993164373	Pin	Schenkel	Fuseé	1
13	947309501534	Hex screw M 12x100	Sechskantschraube M 12x100	Vis hex M 12x100	1
13.1	947311210505	Flat washer B 13	Scheibe B 13	Rondelle B 13	1
13.2	947311214504	Spring washer 12	Scheibe 12	Rondelle 12	1
13.3	947311120504	Hex nut M 12	Sechskantmutter M 12	Ecrou hex M 12	1
14	532092207483	Washer (SP)	Scheibe	Rondelle	1
15	947309201540	Hex screw M 10x80	Sechskantschraube M 10x80	Vis hex M 10x80	2
15.1	947311214503	Spring washer 10	Federscheibe 10	Rondelle 10	2
15.2	947311120503	Hex nut M 10	Sechskantmutter M 10	Ecrou M 10	2
16	532195203533	Bushing	Büchse	Entretoise	2
17	947425111016	Grease fitting MK 8x1	Schmiernippel MK 8x1	Gaisseur MK 8x1	1
18	947532940113	Front tyre wheel 16"-6,50	Front rad 16"-6,50	Roue avant 16"-6,50	2
19	947324196015	Lower steering support 3/4"CARLISLE	Lagerung 3/4" CARLISLE	Palier 3/4" CARLISLE	4
20	947000532135	Tyre valve compl.	Ventil	Valve a pneu	2
21	947000532124	Wheel 16x6.50-8	Felge 16x6.50-8	Jante 16x6.50-8	2
22	947000532123	Tyre 16x6.50-8	Reifen 16x6.50-8	Pneu 16x6.50-8	2
23	947000532125	Tube 16x6.50-8	Schlauch 16x6.50-8	Chambre 16x6.50-8	2
24	532092207393	Washer (SP)	Scheibe	Rondelle	2
25	947311732008	Spring clip "C" 15	Sicherscheibe 15	Clips 15	2
26	947532150208	Cap 38 A/PVC black	Kappe 38 A/PVC schwarz	Couvercle 38 A/PVC noir	2

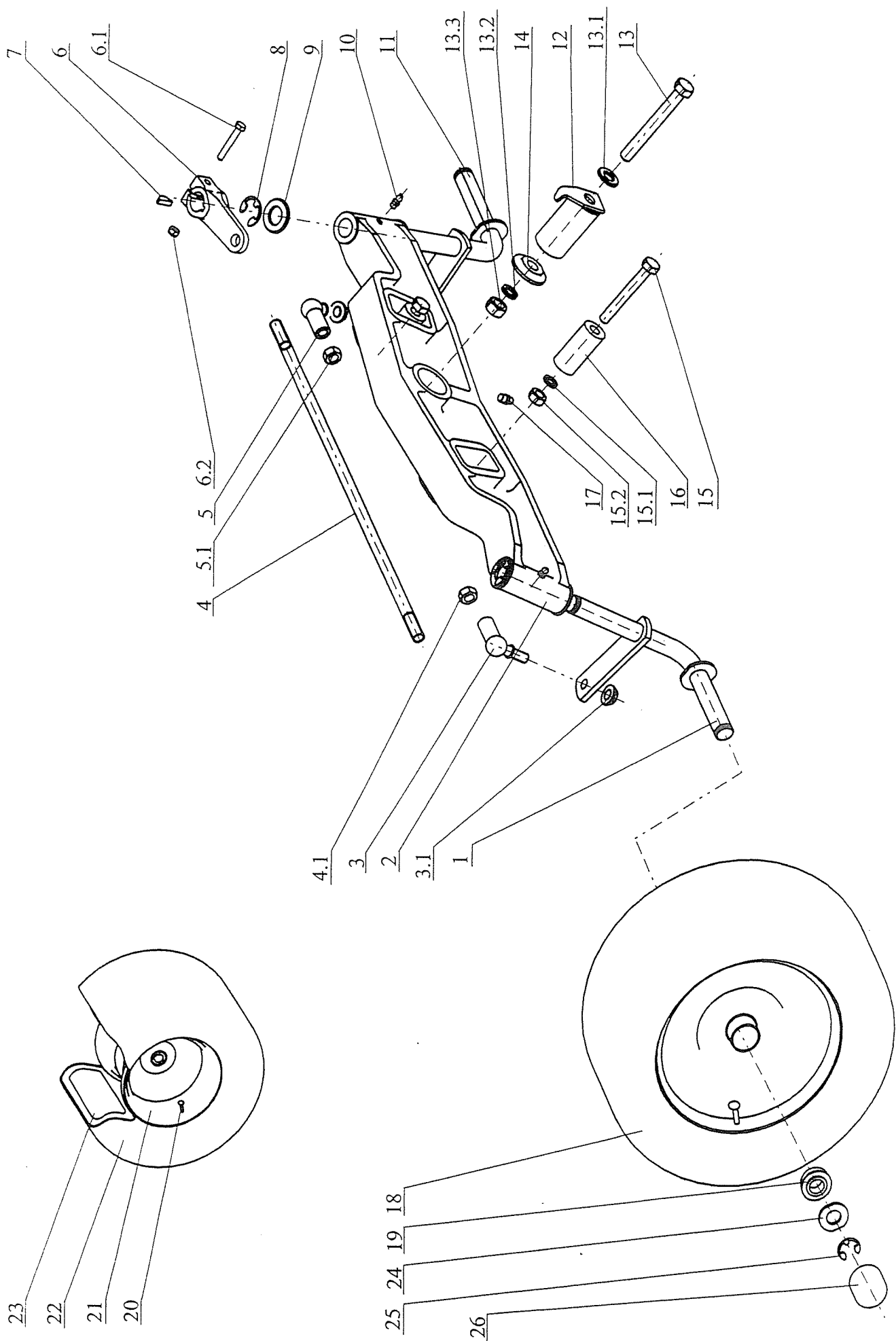

**STEERING  
LENKUNG  
CONDUITE**

**3**

**2004**

Nr.	REF.	DESCRIPTION	BEZEICHNUNG	DESIGNATION	QTY
1	532113322803	Re-inforcement plate	Halter	Plaque	1
2	532033322083	Sector gear	Zahnsegment	Secteur dente	1
3	532080272033	Eccentric	Exenter	Douille excentrique	1
3.1	947425111004	Grease fitting MK 6x1	Schmiernippel MK 6x1	Graisseur MK 6x1	1
4	947442073019	Angular joint 16L DIN71802CSM1	Kugelgelenk 16L DIN 71802CS M	Cercle angulaire 16L DIN71802	1
4.1	947311129521	Nut M12 Tensilok BN190KL	Mutter M12 Tensilok BN190KL	Ecrou M12 Tensilok BN190KL	2
5	947311120539	Nut M12 L	Mutter M12 L	Ecrou M12 G	1
6	947532980125	Tie rod 0-9010-554	Spurstange 0-9010-554	Tige filetee 0-9010-554	1
7	947311120504	Hex nut M 12	Sechskantmutter M 12	Ecrou hex M 12	1
8	947442073020	Angular joint 16P DIN71802CSM1	Kugelgelenk 16P DIN71802 CS M	Cercle angulaire 16P DIN71802	1
9	532938703443	Lower steering support	Lagerung	Palier	1
9.1	532938542063	Lower steering support	Lagerung	Palier	1
9.2	947323721002	Bushing 1920 KU	Büchse 1920 KU	Palier 1920 KU	2
10	947425111004	Grease fitting MK 6x1	Schmiernippel MK 6x1	Graisseur MK 6x1	1
11	947311210530	Flat washer 6.4	Scheibe 6.4	Rondelle 6,4	1
12	947311210514	Flat washer 19	Scheibe 19	Rondelle 19	1
13	947309503557	Screw M 6x18	Schraube M 6x18	Vis M 6x18	2
13.1	947311212516	Flat washer 6.6 zinc.	Scheibe 6.6 zinc.	Rondelle 6.6 zinc	2
13.2	947311129513	Self locking nut M 6	Sichermutter M 6	Ecrou M 6	2
14	947311732008	Spring clip "C" 15	Sicherscheibe 15	Clips 15	1
15	947309578506	Slotted screw M 8x30 DIN	Senkschraube M 8x30 DIN	Vis M 8x30 DIN	1
15.1	947311120520	Nut M 8	Sechskantmutter M 8	Ecrou M 8	1
16	532195202593	Spacer	Buchse	Entretoise	1
17	532930252103	Steering sheft pinion gear	Welle m. Ritzel	Colonne direction	1
18	947309019522	Screw M 12x55-8.8 A3L ISO 8677	Schraube M 12x55-8.8 A3L ISO	Vis M 12x55-8.8 A3L ISO 8677	1
18.1	947311120504	Hex nut M 12	Sechskantmutter M 12	Ecrou hex M 12	2



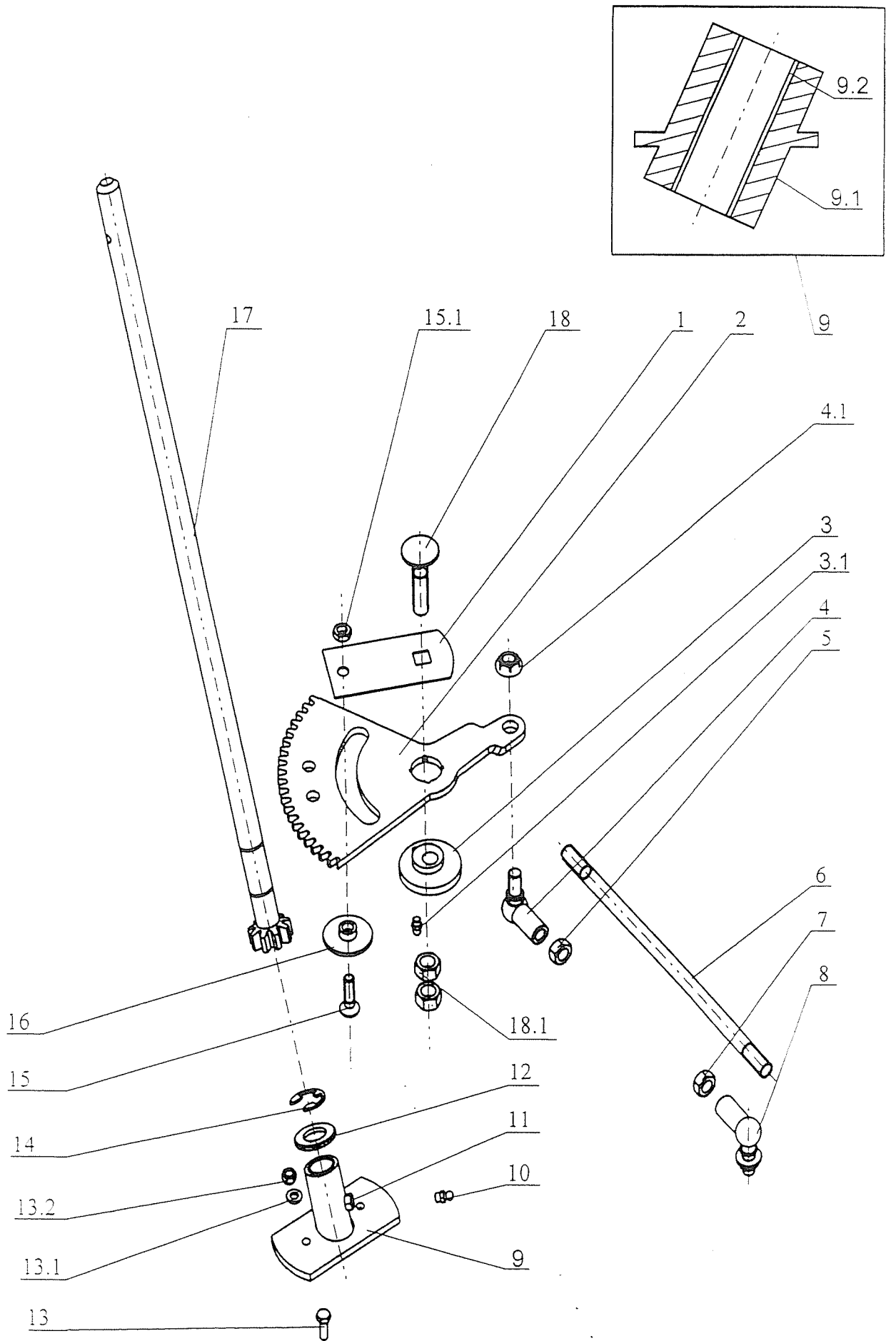

**MAIN FRAME  
RAHMEN  
CHASSIS**

4

2004

Nr.	REF.	DESCRIPTION	BEZEICHNUNG	DESIGNATION	QTY
1	947532150208	Cap 38 A/PVC black	Kappe 38 A/PVC schwarz	Couvercle 38 A/PVC noir	2
2	947311732008	Spring clip "C" 15	Sicherscheibe 15	Clips 15	2
3	532092207393	Washer (SP)	Scheibe	Rondelle	2
4	532092312163	Spring	Feder	Clavette	2
5	947000532094	Rear tyre wheel assy 20x10-8	Hinterrad 20x10.00-8	Roue AR 20x10.00-8	2
6	947272731199	V-belt 13x2550 Li	Riemen 13x2550 Li	Courroie 13x2550 Li	1
7	532936362163	Retainer	Halter	Guide	1
8	947309203504	Hex screw M 8x20	Sechskantschraube M 8x20	Vis hex M 8x20	1
8.1	947311214502	Washer 8	Scheibe 8	Rondelle 8	1
8.2	947311120502	Nut M 8	Sechskantmutter M 8	Ecrou M 8	1
9	947000532010	El. magnet. clutch MSS-80HC	Kupplung kpl.	Embrayage électromagnétique	1
10	947311214012	Spring washer 7/16" zinc	Federscheibe 7/16" zinc	Rondelle à ressort 7/16" zinc	1
11	947309579509	Screw UNF/16"x21/4"10.9Z	Schraube UNF/16x21/4"10.9Z	Vis UNF/16"x21/4"10.9Z	1
12	532912962633	Chassis frame	Fahrgestell	Cadre	1
13	947311120503	Hex nut M 10	Sechskantmutter M 10	Ecrou M 10	1
14	947311214503	Spring washer 10	Federscheibe 10	Rondelle 10	1
15	947311210504	Flat washer B 10,5	Scheibe B 10.5	Rondelle B 10,5	1
16	947000532003	Idler pulley F 3000-0750	Spannrolle F 3000-0750	Poulie F 3000-0750	1
17	532094214503	Bushing	Büchse	Doille	1
18	532913322763	Holder	Halter	Support	1
19	947311129513	Self locking nut M 6	Sichermutter M 6	Ecrou M 6	1
20	947309578514	Screw M 6x50	Schraube M 6x50	Vis M 6x50	1
21	947315231230	Spring 0-9746-487	Feder 0-9746-487	Resort 0-9746-487	1
22	947309203528	Screw M 10x40	Schraube M 10x40	Vis M 10x40	1
23	947311129502	Self locking nut M 10	Sichermutter M 10	Ecrou M 10	4
24	947311210504	Flat washer B 10,5	Scheibe B 10.5	Rondelle B 10,5	4
25	947000532006	Belt pulley V 3000-3316	Keilriemenscheibe V 3000-3316	Poulie V 3000-3316	4
26	532094214183	Bushing	Buchse	Douille	4
27	947309201512	Hex screw M 10x40	Sechskantschraube M 10x40	Vis hex M 10x40	4
28	947000532133	Tube 20x10.00-8	Schlauch 20x10.00-8	Chambre a air 20x10.00-8	2
29	947000532134	Wheel 20x10.00-8	Felge 20x10.00-8	Jante 20x10.00-8	2
30	947000532135	Tyre valve compl.	Ventil	Valve a pneu	2
31	947000532132	Tyre 20x10.00-8	Reifen 20x10.00-8	Pneu 20x10.00-8	2

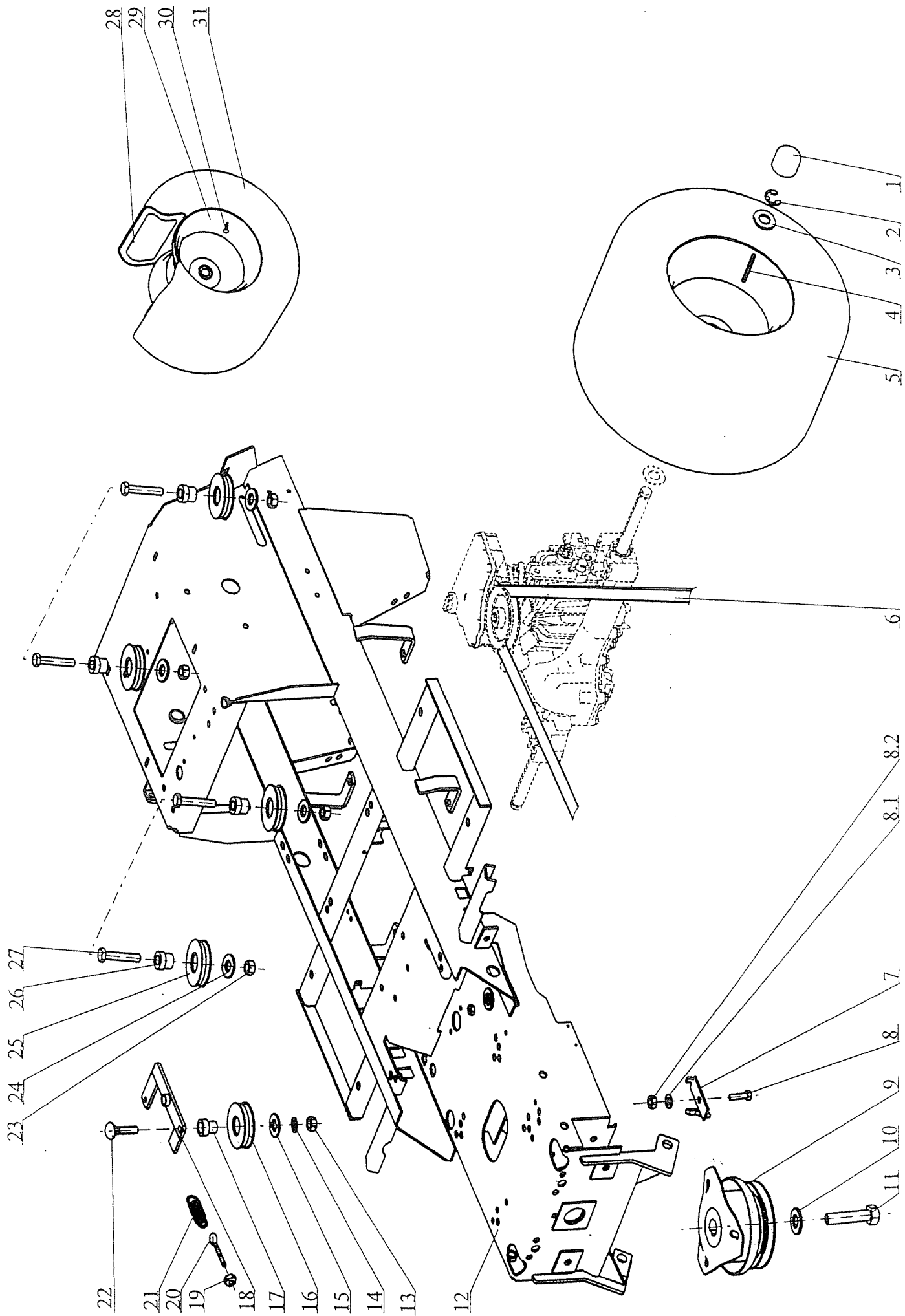

**HYDROSTAT-PEDALS**  
**GETRIEBE-PEDALE**  
**POMPE-PEDALES**

Nr.	REF.	DESCRIPTION	BEZEICHNUNG	DESIGNATION	QTY
1	947532150209	Lever tip 8x40 VINYL-FLEX bl.	Kappe 8x40 VINYL-FLEX schwarz	Capuchon 8x40 VINYL-FLEX noir	1
2	532980712323	Lever	Hebel	Levier	1
3	947309503518	Screw M 8x20	Schraube M 8x20	Vis M 8x20	1
3.1	947311214502	Washer 8	Scheibe 8	Rondelle 8	1
3.2	947311120502	Nut M 8	Sechskantmutter M 8	Ecrou M 8	1
4	532080412363	Holderclamp	Halter	Plaque fixation	1
5	532980442213	Travel lever	Hebel	Levier	1
6	947311338517	Cotter pin 3.2x25	Spannstift 3.2x25	Goupille 3.2x25	3
7	947273151001	Pedal rubber 65501	Pedal gummi 65501	Couvre de pédale 65501	2
8	532980512573	Pedal	Pedal	Pédale	2
9	947309203530	Hex screw M 8x35	Sechskantschraube M 8x35	Vis hex M 8x35	2
9.1	947311120502	Nut M 8	Sechskantmutter M 8	Ecrou M 8	2
10	947309203504	Hex screw M 8x20	Sechskantschraube M 8x20	Vis hex M 8x20	3
10.1	947311129501	Self locking nut M 8	Sicherungsmutter M 8	Ecrou de blocage M 8	3
11	947315238050	Spring pin 5x20	Splannstift 5x20	Goupille 5x20	2
12	532980365183	Shoe	Pratze	Soulier	1
13	947722643023	Bushing 0-9462-202	Büchse 0-9462-202	Douille 0-9462-202	4
14	532080412873	Brake connection rod	Bremsstange	Tige	1
15	532113403863	Holder	Halter	Support	1
16	532092303943	Washer	Scheibe	Rondelle	2
17	947309501571	Screw M 8x80	Schraube M 8x80	Vis M 8x80	4
17.1	947311210503	Falt washer 8.4	Scheibe 8.4	Rondelle 8.4	8
17.2	947311214502	Washer 8	Scheibe 8	Rondelle 8	4
17.3	947311120502	Nut M 8	Sechskantmutter M 8	Ecrou M 8	4
18	532090164473	Screw	Schraube	Vis	1
18.1	947311129502	Self locking nut M 10	Sichermutter M 10	Ecrou M 10	1
19	947315231240	Spring TLZ 250.150.0530	Feder TLY 250.150.0530	Resort TLZ 250.150.0530	1
20	947311212517	Washer 9 zinc.	Scheibe 9 zinc	Rondelle 9 zinc	1
21	947311120520	Nut M 8	Sechskantmutter M 8	Ecrou M 8	2
22	532092208153	Washer	Scheibe	Rondelle	10
23	532195203503	Bushing	Büchse	Douille	2
24	532092207393	Washer (SP)	Scheibe	Rondelle	4
25	947532991052	Gear box TUFF TORQ K46	Getriebe TUFF TORQ K46	Boite TUFF TORQ K46	1
26	947309203506	Screw M 8x45	Schraube M 8x45	Vis M 8x45	1
26.1	947311210503	Falt washer 8.4	Scheibe 8.4	Rondelle 8.4	1
26.2	947311129501	Self locking nut M 8	Sicherungsmutter M 8	Ecrou de blocage M 8	1
27	947311338513	Cotter pin 1.6x12	Splint 1.6x12	Goupille 1.6x12	1
27.1	947311210502	Flat washer 6.4	Scheibe 6.4	Rondelle 6.4	1
28	947309203539	Hex screw M 5x16	Sechskantschraube M 5x16	Vis hex M 5x16	2
28.1	947311214507	Spring washer 5	Scheibe 5	Rondelle 5	2
28.2	947311120506	Nut M 5	Sechskantmutter M 5	Ecrou M 5	2
29	532113403913	Holder	Halter	Support	1
30	532080452513	Tie rod Bypass	Spurstange Bypass	Tige Bypass	1
31	947442073018	Spring clip 13 DIN71805	Epingle 13 DIN71805	Sicherungsbügel 13 DIN71805	1
32	947442073012	Ball joint 13 DIN71803C zink.	Rotule 13 DIN71803C zink.	Kugelgelenk 13 DIN71803 zink.	1
33	947311129520	Matrice M8 Tensilok	Mutter M8 Tensilok	Ecrou M8 Tensilok	1
34	947442073016	Ball joint 13 DIN 71805B zink.	Rotule 13 DIN71805B zink.	Kugelgelenk 13 DIN71805B zink.	1
35	947311150503	Nut M8	Mutter M8	Ecrou M8	1
36	532913368443	Holder	Halter	Support	1
37	532980512583	Pedal	Pedal	Pédale	1
38	947273151011	Pedal pad FAVORIT	Pedal gummi FAVORIT	Cautchouc de pédale FAVORIT	1
39	947315238037	Spring pin 5x22	Splannstift 5x22	Goupille 5x22	1
40	532980364823	Arm	Arm	Bras	1
41	532980422103	Travel tie rod	Spurstange	Tige	1
42	947311338501	Cotter pin 2x20	Splint 2x20	Goupille 2x20	1
43	532195203493	Bushing	Büchse	Douille	3
44	532980442263	Brake pedal	Bremsepedal	Pédale	1
45	947315231160	Spring 0-9746-444	Zugfeder 0-9746-444	Ressort 0-9746-444	1
46	947345329014	Switch 1022.4501	Schalter1022.4501	Interrupteur lames 1022.4501	1
47	947358352009	Speed control 9-8032-214	Tempogerät 9-8032-214	Temps 9-8032-214	1
47.1	532094214403	Brake wheel	Bremsering	Disque	1
47.2	947315231236	Spring 0-9746-488	Feder 0-9746-488	Resort 0-9746-488	1
47.3	947315238037	Spring pin 5x22	Splannstift 5x22	Goupille 5x22	1
48	947309578507	Screw M 4x8 D 7500 D	Schraube M 4x8 D 7500 D	Vis M 4x8 D 7500 D	1
49	947315231161	Spring 0-9746-445	Zugfeder 0-9746-445	Ressort 0-9746-445	1

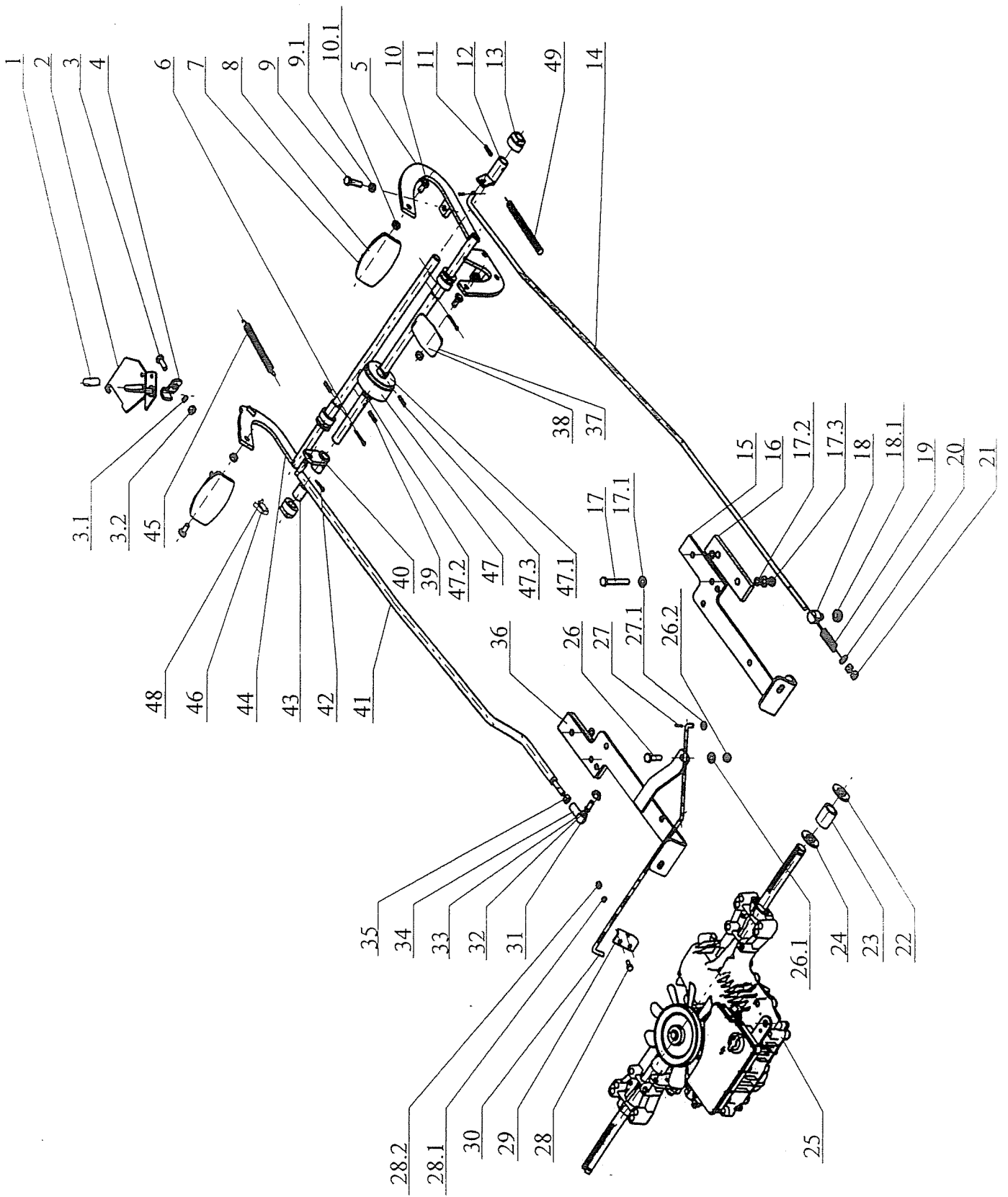

**HIGHT ADJUSTMENT**  
**MÄHWERK-HÖHENEINSTELLUNG**  
**HAUTEUR DE COUPE**

6

2004

Nr.	REF.	DESCRIPTION	BEZEICHNUNG	DESIGNATION	QTY
1	532037322183	Section gear	Zahnsegment	Secteur	1
2	947722643016	Plunger button 0-8025-234	Knopf 0-8025-234	Bouton 0-8025-234	1
3	947532150049	Handle grip 0-8060-236	Handgriff 0-8060-236	Poignee 0-8060-236	1
4	532980522163	Height adj. arm lever	Hebel	Levier, complet	1
5	947315238034	Connecting rod 0-8045-237	Stange 0-8045-237	Tige 0-8045-237	1
6	947315231158	Spring 0-9746-439	Zugfeder 0-9746-439	Ressort 0-9746-439	1
7	532037322113	Ratchet pivot plate	Klinke	Cliquet	1
8	947309203517	Hex screw M 8x25	Sechskantschraube M 8x25	Vis M 8x25	1
8.1	947311129501	Self locking nut M 8	Sicherungsmutter M 8	Ecrou de blocage M 8	1
9	947309503512	Screw M 8x25	Schraube M 8x25	Vis M 8x25	3
9.1	947311214502	Washer 8	Scheibe 8	Rondelle 8	3
9.2	947311120502	Nut M 8	Sechskantmutter M 8	Ecrou M 8	3
10	532113414183	Holder	Halter	Support	1
11	947722643022	Bushing 0-9462-201	Büchse 0-9462-201	Douille 0-9462-201	3
12	532980462853	Arm	Arm	Bras	2
13	947315238041	Spring pin 6x30	Spannstift 6x30	Cheville élastique 6x30	2
14	532080402683	Tie rod	Spurstange	Tirant	2
15	947311210503	Falt washer 8.4	Scheibe 8.4	Rondelle 8.4	2
16	947311120502	Nut M 8	Sechskantmutter M 8	Ecrou M 8	4
17	532038102853	Shaft	Welle	Arbre de couche	1
18	947309501568	Screw M 6x35	Schraube M 6x35	Vis M 6x35	2
18.1	947311129513	Self locking nut M 6	Sichermutter M 6	Ecrou M 6	2
19	532090164473	Screw	Schraube	Vis	2
19.1	947311129502	Self locking nut M 10	Sichermutter M 10	Ecrou M 10	2
19.2	532195203273	Spacer	Hülse	Entretoise	2
20	532094214373	Ring	Ring	Anneau	2
21	947311338506	Cotter pin 3.2x18	Spannstift 3.2x18	Clavette 3.2x18	2
22	947311210503	Falt washer 8.4	Scheibe 8.4	Rondelle 8.4	2
23	947722643022	Bushing 0-9462-201	Büchse 0-9462-201	Douille 0-9462-201	2
24	532980508103	Pivot arm assy	Verstellhebel	Bras relevage	1
25	947311338517	Cotter pin 3.2x25	Spannstift 3.2x25	Goupille 3.2x25	2
26	532114327223	Shoe	Pratye	Soulier	1
27	947309578511	Screw M 8x20 BN 9524 zinc	Schraube M 8x20 BN 9524 zink	Vis M 8x20 BN 9524 zinc	2
27.1	947311129501	Self locking nut M 8	Sicherungsmutter M 8	Ecrou de blocage M 8	2
28	532993462153	Pin	Bolzen	Axe	2
29	947315238003	Hair pin clip 0-9245-999	Federstecker 0-9245-999	Épingle 0-9245-999	2
30	947315231165	Spring 0-9746-465	Zugfeder 0-9746-465	Ressort 0-9746-465	1
31	947309599018	Screw 9-9016-312	Schraube 9-9016-312	Vis 9-9016-312	1
32	947311214503	Spring washer 10	Federscheibe 10	Rondelle 10	1
33	947311120503	Hex nut M 10	Sechskantmutter M 10	Ecrou M 10	1

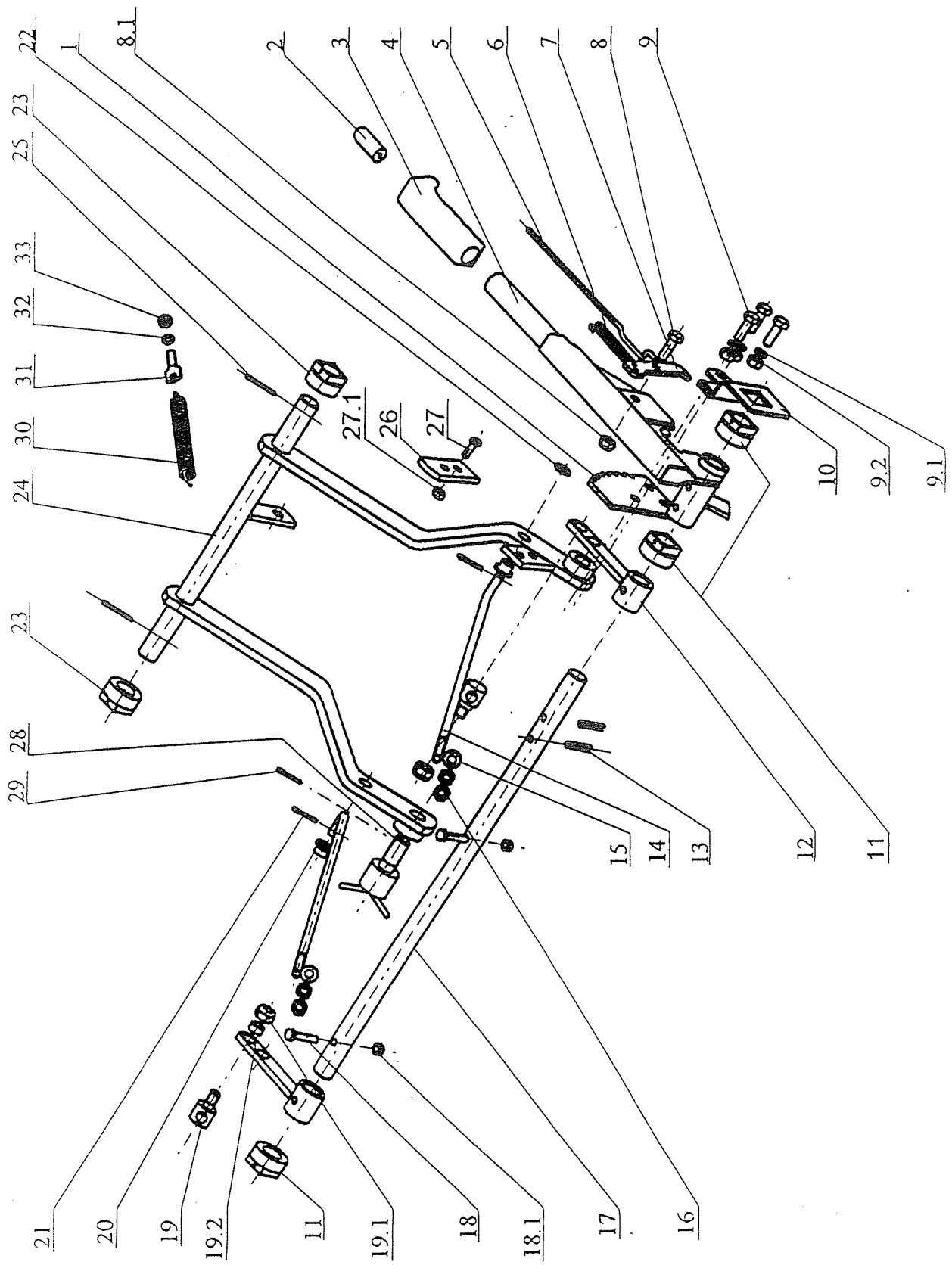

**CUTTING PAN ASSY**  
**MÄHWERK**  
**TONDEUSE**

7

2004

Nr.	REF.	DESCRIPTION	BEZEICHNUNG	DESIGNATION	QTY
1	532990362343	Speedclutch	Schnellkuplung	Avec d'embrayage	2
1.1	947311120511	Hex nut M 12	Sechskantmutter M 12	Ecrou hex M 12	2
1.2	947273111054	Ring 12x2	Rad 12x2	Anneau 12x2	2
1.3	532090262463	Speedclutch	Schnellkuplung	Avec d'embrayage	2
2	947309503518	Screw M 8x20	Schraube M 8x20	Vis M 8x20	6
3	947309201524	Hex screw M 8x90	Sechskantschraube M 8x90	Vis hex M 8x90	4
4	532195202623	Spacer	Hülse	Entretoise	4
5	947532940086	Gauge wheel Mouldex	Tasrad Mouldex	Roulette Mouldex	4
6	947311129501	Self locking nut M 8	Sicherungsmutter M 8	Ecrou de blocage M 8	4
7	947311726009	Square key 6h9x6x30	Passfeder 6h9x6x30	Clavette 6hx9x6x30	1
8	532038128023	Blade shaft	Messerwelle	Arbre	1
9	947309599008	Screw M 10x1x35 left	Schraube M 10x1x35 links	Vis pas inverse M 10x1x35 g.	1
10	532050422533	Blade right	Messer, rechts	Lame droit	1
11	532050422543	Blade left	Messer, links	Lame gauche	1
12	947309599017	Hex screw 0-9011-287 M10	Sechskantschraube 0-9011-287	Vis hex 0-9011-287 M 10	1
13	532092207493	Washer	Scheibe	Rondelle	2
14	947311219503	Conical washer BN 806-40x16.3	Scheibe BN 806-40x16.3x2x3.1	Rondelle BN 806-40x16.3x2x3.1	2
15	947532980077	Breaking pin 0-9311-736	Schärstift 0-9311-736	Goupille sécurité 0-9311-736	4
16	532098212403	Blade adaptor	Messerlager	Palier	2
17	947311726014	Square key 9x6x25	Passfeder 9x6x25	Clavette 9x6x25	2
18	947324162099	Bearing 6205 A 2RS	Lager 6205 A 2RS	Palier 6205 A 2RS	4
19	947311733014	Locking ring 25	Sicherungsring 25	Anneau de retenue 25	2
20	532038128033	Blade shaft	Messerwelle	Arbre	1
21	947311726019	Key 6h9x6x63	Passfeder 6h9x6x63	Clavete 6hx9x63	1
22	532950472083	Mower housing assy	Mähergehäuse	Capotage des couteaux, complet	1
23	532193102893	Pin	Achse	Axe	1
23.1	947315238035	Hair pin clip 0-9245-240	Federstecker 0-9245-240	Epingle 0-9245-240	2
24	947309503543	Screw M 8x35	Flachschrabe M 8x35	Vis M 8x35	6
25	532098203373	Brace	Stütze des Mähwerks	Renfort	2
26	532038523833	Quill housing	Messerlager	Palier	2
27	947311129501	Self locking nut M 8	Sicherungsmutter M 8	Ecrou de blocage M 8	6
27.1	947311210503	Falt washer 8.4	Scheibe 8.4	Rondelle 8.4	6
28	532080503503	Front suspension mower deck	Anhängung, vorn	Attelage AV	1
29	947315238003	Hair pin clip 0-9245-999	Federstecker 0-9245-999	Epingle 0-9245-999	2
29.1	947311613002	Pin 1-9310-290	Boizen 1-9310-290	Axe 1-9310-290	2



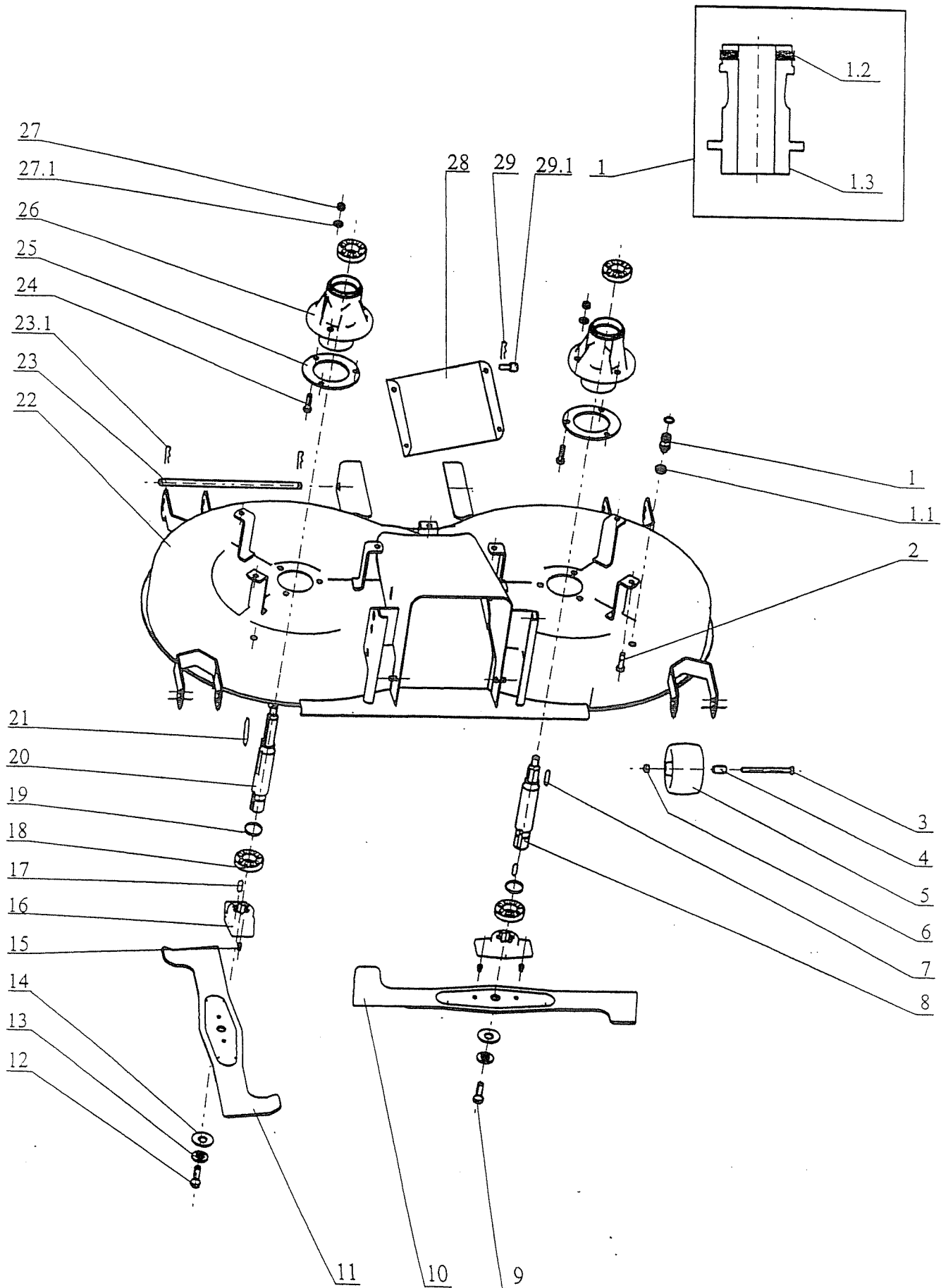

**CUTTING PAN ASSY  
MÄHWERK  
TONDEUSE**

7

2004

Nr.	REF.	DESCRIPTION	BEZEICHNUNG	DESIGNATION	QTY
30	947272731193	V-belt B17x1350 KREBS	Keilriemen B17x1350 KREBS	Courroie trapéz. B17x1350	1
31	947311120520	Nut M 8	Sechskantmutter M 8	Ecrou M 8	2
32	532113402353	Engagement lever	Lasche	Plaque	1
33	947311120502	Nut M 8	Sechskantmutter M 8	Ecrou M 8	1
34	947311214502	Washer 8	Scheibe 8	Rondelle 8	1
35	947311212508	Flat washer 9 zinc.	Scheibe 9 zinc	Rondelle 9 zinc	1
36	947000532002	Idler pulley W 3500-3712	Spannrolle W 3500-3712	Poulie W 3500-3712	1
37	532093212633	Pin	Buchse	Douille	1
38	532913422403	Idler arm assy	Halter	Bras tendeur	1
39	947309203537	Hex screw M 6x18	Sechskantschraube M 6x18	Vis hex M 6x18	2
39.1	947311212516	Flat washer 6.6 zinc.	Scheibe 6.6 zinc.	Rondelle 6.6 zinc	4
40	947532150210	Belt cover 0-8547-369	Abdeckung 0-8547-369	Cache plastique 0-8547-369	1
41	947311129505	Self locking nut M 12	Sichermutter M 12	Ecrou de sécurité M 12	2
41.1	947311210505	Flat washer B 13	Scheibe B 13	Rondelle B 13	2
42	947311733079	Locking ring 40	Sicherring 40	Rondelle 40	2
43	947324162098	Bearing 6203 2RS	Lager 6203 2RS	Palier 6203 2RS	2
44	532933712743	Pulley	Keilriemenscheibe	Poulie	2
45	947311120502	Nut M 8	Sechskantmutter M 8	Ecrou M 8	2
45.1	947311212517	Washer 9 zinc.	Scheibe 9 zinc	Rondelle 9 zinc	1
45.2	532914412313	Lug	Lappen	Patte	1
46	532092207533	Wascher	Scheibe	Rondelle	1
47	532993122683	Pin	Stift	Douille	1
48	532092207703	Washer	Scheibe	Rondelle	1
49	532096303973	Brace	Stütze	Renfort	1
50	532985423313	Blade drive plate assy	Platte	Plaque	1
51	947311129513	Self locking nut M 6	Sichermutter M 6	Ecrou M 6	2
52	532092303963	Brace	Stütze	Renfort	1
53	947311129505	Self locking nut M 12	Sichermutter M 12	Ecrou de sécurité M 12	2
54	947311129501	Self locking nut M 8	Sicherungsmutter M 8	Ecrou de blocage M 8	1
55	947309019501	Screw M 8x20	Schraube M 8x20	Vis M 8x20	2
55.1	947311210505	Flat washer B 13	Scheibe B 13	Rondelle B 13	2
55.2	947311210503	Falt washer 8.4	Scheibe 8.4	Rondelle 8.4	2
55.3	947311129501	Self locking nut M 8	Sicherungsmutter M 8	Ecrou de blocage M 8	2
56	947311129501	Self locking nut M 8	Sicherungsmutter M 8	Ecrou de blocage M 8	6
57	947309503518	Screw M 8x20	Schraube M 8x20	Vis M 8x20	1
57.1	947311214502	Washer 8	Scheibe 8	Rondelle 8	1
57.2	947311210503	Falt washer 8.4	Scheibe 8.4	Rondelle 8.4	1
58	947309203517	Hex screw M 8x25	Sechskantschraube M 8x25	Vis M 8x25	1
59	532933712773	Pulley	Keilriemenscheibe	Poulie	2
60	532092207273	Washer	Scheibe	Rondelle	1
61	947311129505	Self locking nut M 12	Sichermutter M 12	Ecrou de sécurité M 12	1
62	947272211006	Cog belt DS8M1760	Zahnriemen DS8M1760	Courroie crantée DS8M1760	1
63	947311129513	Self locking nut M 6	Sichermutter M 6	Ecrou M 6	2
64	947311212516	Flat washer 6.6 zinc.	Scheibe 6.6 zinc.	Rondelle 6.6 zinc	2
65	532085342013	Cover	Abdeckung	Capot	1
66	532985402733	Bracket	Spreize	Entretoise	1
67	947532150165	Pulley 9-3325-234	Keilriemenscheibe 9-3325-234	Poulie 9-3325-234	1
68	532092207273	Washer	Scheibe	Rondelle	1
69	947311129505	Self locking nut M 12	Sichermutter M 12	Ecrou de sécurité M 12	1
70	532092212223	Washer	Scheibe	Rondelle	1
71	947311214502	Washer 8	Scheibe 8	Rondelle 8	1
72	947309543506	Hexagon socket screw M 8x20	Schraube M 8x20	Vis hex M 8x20	1
73	947315231193	Spring 0-9746-460	Feder 0-9746-460	Ressort 0-9746-460	1

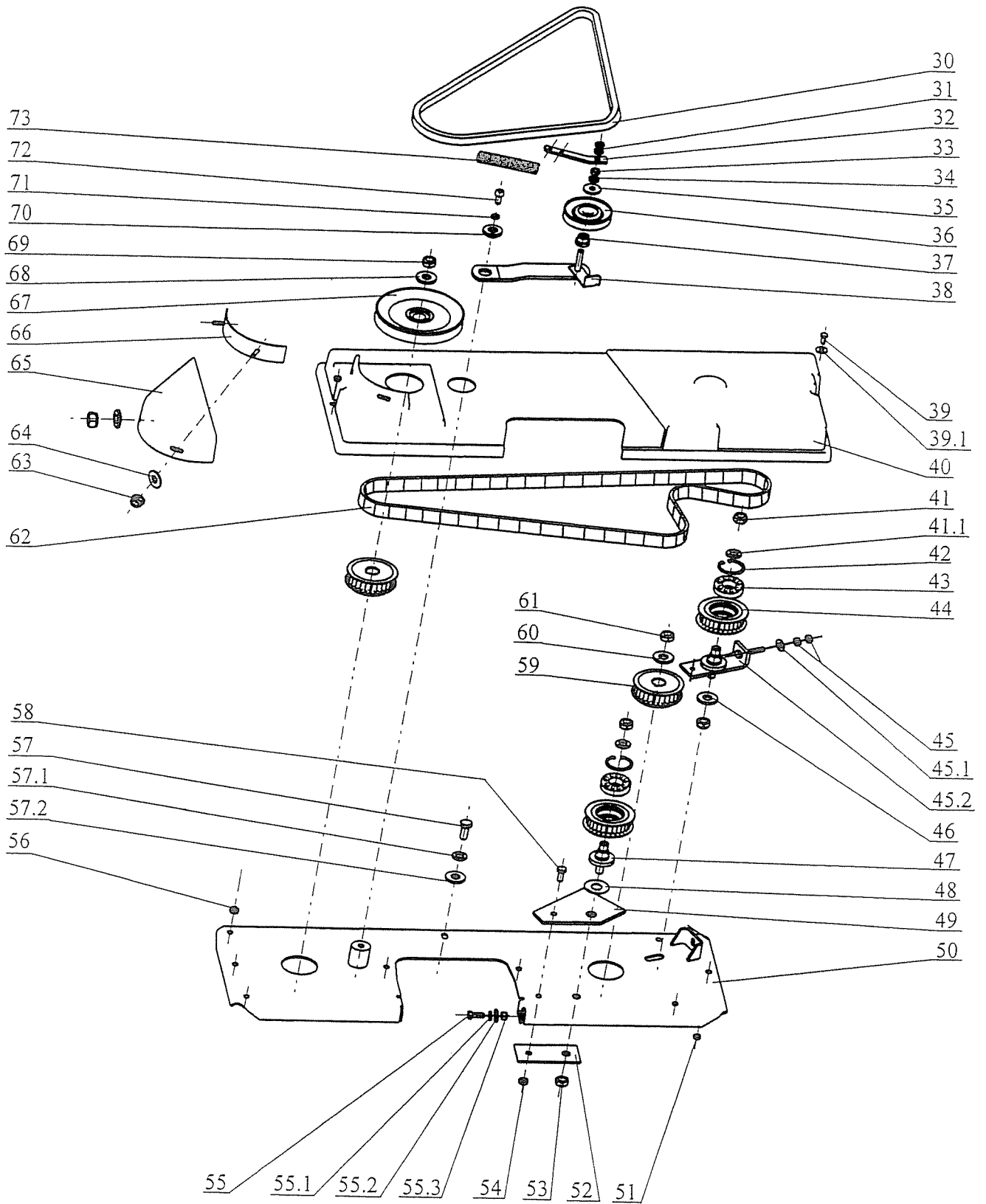

**TUNNEL-CATCHER SUPPORT  
TUNNEL-HINTERPLATTE  
TUNNEL-SUPPORT Bac**

9

2004

Nr.	REF.	DESCRIPTION	BEZEICHNUNG	DESIGNATION	QTY
1	532974432173	Holder R	Halter R	Support D	1
2	532096362013	Rubber seal	Dämmeinlage	Joint caoutchouc	1
3	947309578011	Hex screw M 8x25 DIN69218.8	Sechskantschraube M 8x25 DIN	Vis hex M 8x25 DIN69218.8	6
3.1	947311210503	Falt washer 8.4	Scheibe 8.4	Rondelle 8.4	6
3.2	947311214502	Washer 8	Scheibe 8	Rondelle 8	6
3.3	947311120502	Nut M 8	Sechskantmutter M 8	Ecrou M 8	6
4	532974432163	Holder L	Halter L	Support G	1
5	532113402453	Tow hitch	Anhängevorrichtung	Plaque d'attelage	1
6	947309578011	Hex screw M 8x25 DIN69218.8	Sechskantschraube M 8x25 DIN	Vis hex M 8x25 DIN69218.8	4
6.1	947311210503	Falt washer 8.4	Scheibe 8.4	Rondelle 8.4	4
6.2	947311214502	Washer 8	Scheibe 8	Rondelle 8	4
6.3	947311120502	Nut M 8	Sechskantmutter M 8	Ecrou M 8	4
7	532085352033	Key	Klappe	Clapet	1
8	947309019520	Screw M 5x20 zinc	Schraube M 5x20 zinc	Vis M 5x20 zinc	1
8.1	947311120530	Hex nut M 5	Sechskantmutter M 5	Ecrou M 5	2
9	947309203559	Screw M 6x35	Schraube M 6x35	Vis M 6x35	1
9.1	947311120513	Hex nut M 6	Sechskantmutter M 6	Ecrou M 6	1
10	947311338514	Cotter pin 2x16	Federstift 2x16	Goupille 2x16	2
11	532014102103	Pin	Stift	Goupille	1
12	947311210502	Flat washer 6.4	Scheibe 6.4	Rondelle 6.4	2
13	947309231529	Screw M 4x8	Schraube M 4x8	Vis M 4x8	1
14	947315231195	Spring 0-9746-462	Druckfeder 0-9746-462	Ressort 0-9746-462	1
15	532913462413	Holder	Halter	Support	1
16	947309203539	Hex screw M 5x16	Sechskantschraube M 5x16	Vis hex M 5x16	4
16.1	947311129515	Locking nut M 5	Mutter M 5	Ecrou M 5	4
17	532113403233	Tow hitch support	Verstärkung	Tole angulaire	1
18	532974472253	Tunnel-discharge	Auswurfschacht	Tunnel	1
19	947309231502	Screw M 4x12 cyl.head-slotted	Zylinderschraube M 4x12	Vis M 4x12	3
19.1	947311120505	Nut M 4	Mutter M 4	Ecrou M 4	3
20	532115308573	Support plate	Lasche	Rondelle	1
21	532113322813	Screen	Blende	Joint caoutchouc	1
22	532974422193	Collector platte assy	Ruckwand	Tablier arrière	1
23	947309503005	Screw M 8x25 VERBUS RIP KI 10	Sperzahnschraube M 8x25 KL 100	Vis M 8x25 KL 100 RIPP zinc	2

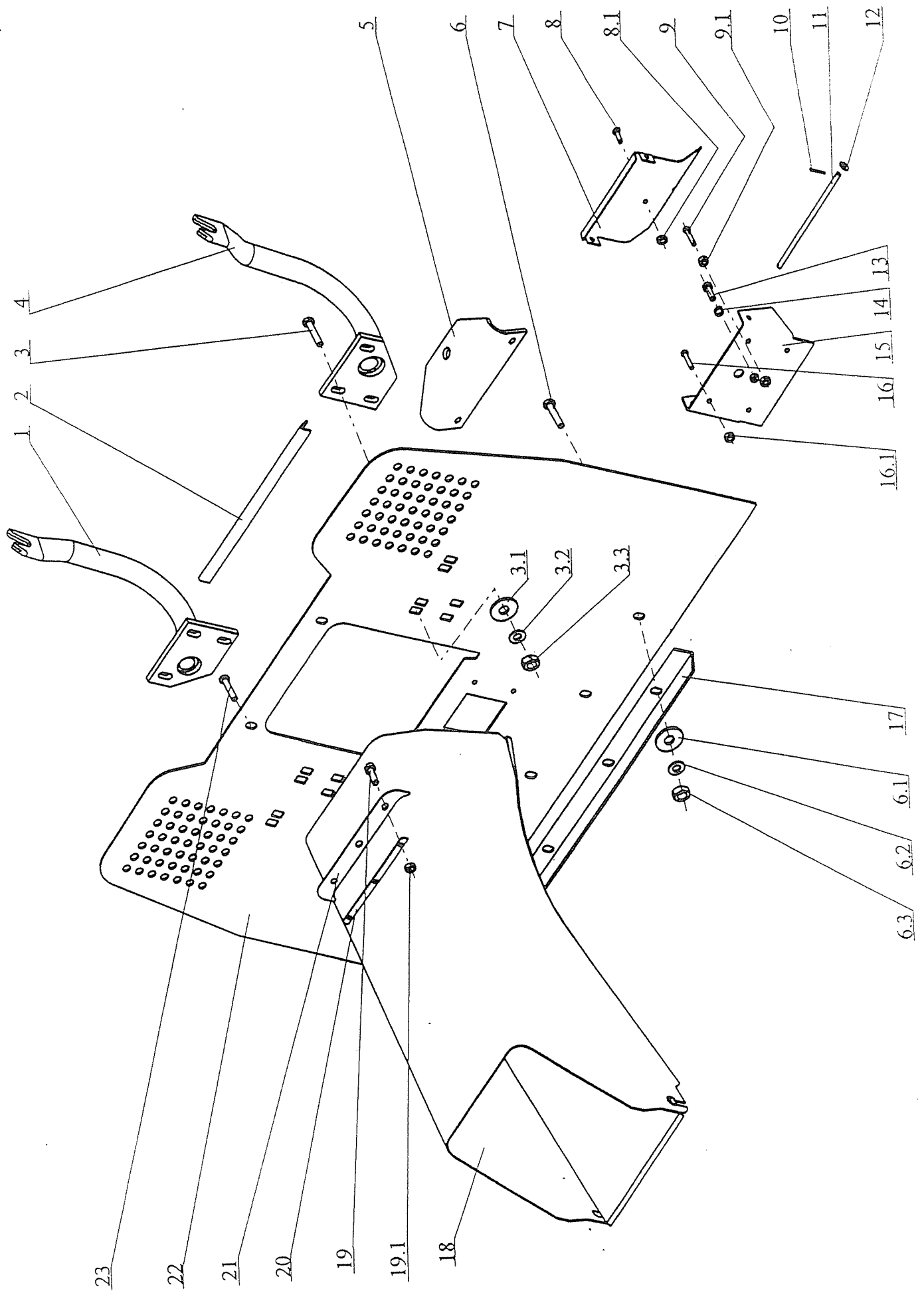

**GRASS CATCHER  
GRASFANGKORB  
BAC RECOLTEUR**

10

2004

Nr.	REF.	DESCRIPTION	BEZEICHNUNG	DESIGNATION	QTY
1	947532150007	Handle grip R/CM PR.25	Griffhülse R/CM 25	Poignée R/CM 25	1
2	532074202013	Dumping lever	Rohr	Levier de basculement	1
3	947309203548	Hex screw M 5x12	Sechskantschraube M 5x12	Vis M 5x12	1
3.1	947311129515	Locking nut M 5	Mutter M 5	Ecrou M 5	1
4	947309203555	Hex screw M 5x30	Sechskantschraube M 5x30	Vis hex M 5x30	6
4.1	947311210501	Flat washer 5.3	Scheibe 5.3	Rondelle 5.3	6
4.2	947311212514	Flat washer 5.5 zinc.	Scheibe 5.5 zinc.	Rondelle 5.5 zinc.	6
4.3	947311129515	Locking nut M 5	Mutter M 5	Ecrou M 5	6
5	947532150135	Grass collector BAG 9-7432-202	Fangsack 9-7432-202	Sac a herbe 9-7432-202	1
6	947309203557	Hex screw M 5x25	Sechskantschraube M 5x25	Vis hex M 5x25	4
6.1	947311210501	Flat washer 5.3	Scheibe 5.3	Rondelle 5.3	4
6.2	947311129515	Locking nut M 5	Mutter M 5	Ecrou M 5	4
7	532974472293	Top framme assy	Gestelloberteil	Cadre superieur	1
8	532074422263	Right corner support	Stütze, rechts	Renfort droit	1
9	532074422273	Left corner support	Stütze, links	Renfort gauche	1
10	532074262013	Connecting brace	Verstärkung	Tube	1
11	947309203556	Hex screw M 5x35	Sechskantschraube M 5x35	Vis hex M 5x35	2
11.1	947311210501	Flat washer 5.3	Scheibe 5.3	Rondelle 5.3	2
11.2	947311129515	Locking nut M 5	Mutter M 5	Ecrou M 5	2
12	532974462013	Bottom frame assy	Bügel	Tube interieur	1
13	532074262023	Brace	Verstärkung	Tube	2
14	947309203555	Hex screw M 5x30	Sechskantschraube M 5x30	Vis hex M 5x30	2
14.1	947311210501	Flat washer 5.3	Scheibe 5.3	Rondelle 5.3	2
14.2	947311129515	Locking nut M 5	Mutter M 5	Ecrou M 5	2
15	532974442013	Front frame assy	Rahmen vorne	Cadre AV	1
16	947309203539	Hex screw M 5x16	Sechskantschraube M 5x16	Vis hex M 5x16	2
16.1	947311210501	Flat washer 5.3	Scheibe 5.3	Rondelle 5.3	2
16.2	947311129515	Locking nut M 5	Mutter M 5	Ecrou M 5	2
17	947309019514	Carriage bolt M 5x16	Schraube M 5x16	Vis M 5x16	4
17.1	947311212514	Flat washer 5.5 zinc.	Scheibe 5.5 zinc.	Rondelle 5.5 zinc.	4
17.2	947311129515	Locking nut M 5	Mutter M 5	Ecrou M 5	4
18	947309203504	Hex screw M 8x20	Sechskantschraube M 8x20	Vis hex M 8x20	2
18.1	947311214502	Washer 8	Scheibe 8	Rondelle 8	2
18.2	947311212508	Flat washer 9 zinc.	Scheibe 9 zinc	Rondelle 9 zinc	2
19	532980202103	Lift handle	Griffstück	Poignée	1
20	947321841053	Collector cover 0-7447-228	Deckel 0-7447-228	Couvercle 0-7447-228	1
21	532097402153	Spring	Winkelblech	Resort	1
22	947309251313	Screw M 5x12	Schraube M 5x12	Vis M 5x12	2
22.1	947311129515	Locking nut M 5	Mutter M 5	Ecrou M 5	2

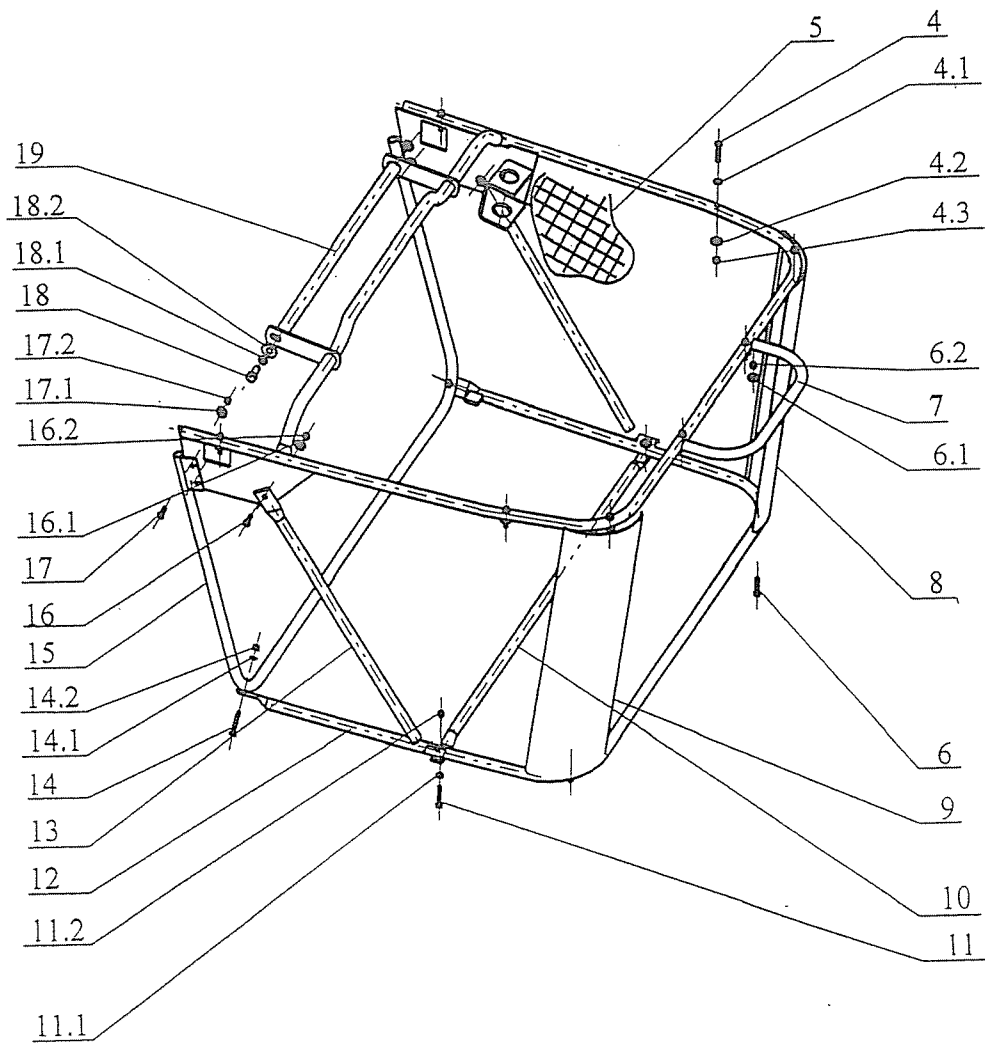
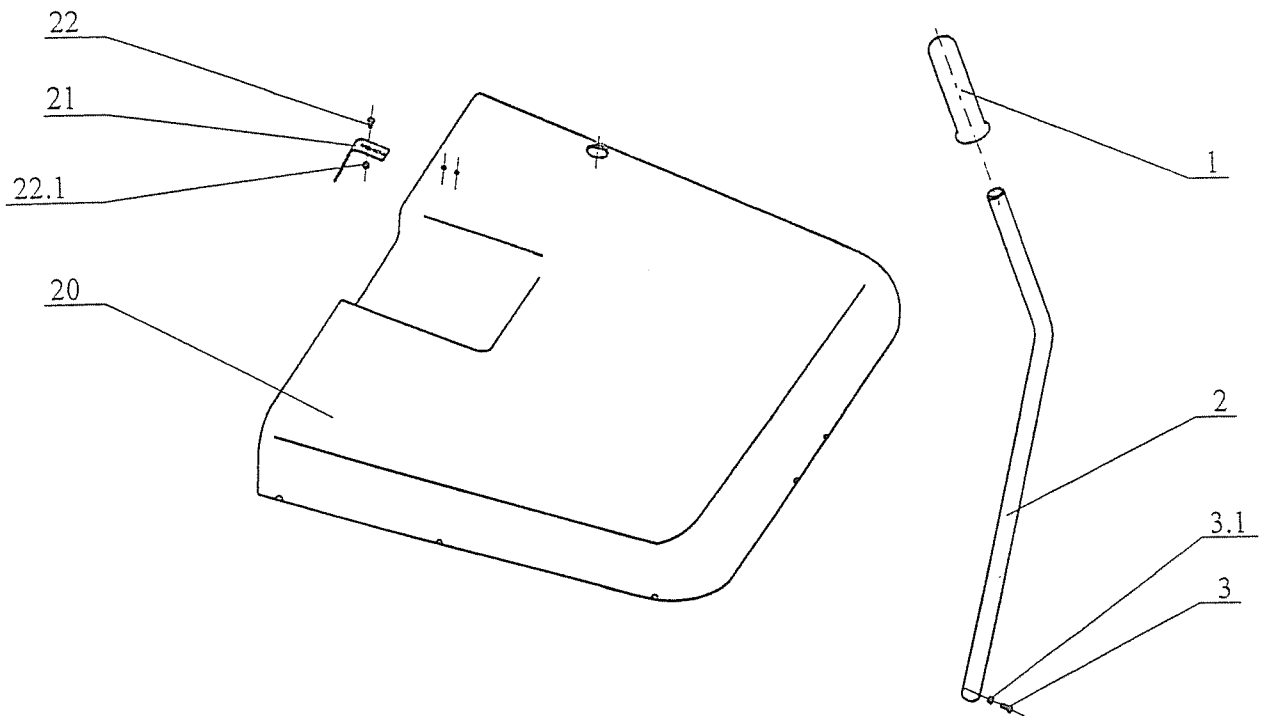

**DASH BOARD  
ARMATURENBRETT  
TABLEAU DE BORD**

11

2004

Nr.	REF.	DESCRIPTION	BEZEICHNUNG	DESIGNATION	QTY
1	532113413343	Fuel tank holder	Tankhalter	Support	1
2	532113403143	Holder	Halter	Support	1
3	947309203548	Hex screw M 5x12	Sechskantschraube M 5x12	Vis M 5x12	2
3.1	947311214507	Spring washer 5	Scheibe 5	Rondelle 5	2
3.2	947311120506	Nut M 5	Sechskantmutter M 5	Ecrou M 5	2
4	947315238005	Spring clip 0-9245-233	Federstecker 0-9245-233	Goupille elastique 0-9245-233	1
5	947273121027	Bushing 22x2	Tülle 22x2	Douille 22x2	1
6	532013424373	Brace	Konsole	Console	1
7	947309203539	Hex screw M 5x16	Sechskantschraube M 5x16	Vis hex M 5x16	6
7.1	947311212514	Flat washer 5.5 zinc.	Scheibe 5.5 zinc.	Rondelle 5.5 zinc.	4
7.2	947311210501	Flat washer 5.3	Scheibe 5.3	Rondelle 5.3	2
7.3	947311129515	Locking nut M 5	Mutter M 5	Ecrou M 5	6
8	947273121014	Bushing 9x2	Tülle 9x2	Douille 9x2	1
9	532980472093	Steering columm	Sockel	Carter	1
10	947309203517	Hex screw M 8x25	Sechskantschraube M 8x25	Vis M 8x25	4
10.1	947311214502	Washer 8	Scheibe 8	Rondelle 8	4
10.2	947311212517	Washer 9 zinc.	Scheibe 9 zinc	Rondelle 9 zinc	4
11	532096342073	Trim	Dichtung	Joint	2
12	947309251511	Screw M4x16	Schraube M4x16	Vis M4x16	2
12.1	947311129514	Self locking nut M 4	Sichermutter M 4	Ecrou M 4	2
13	532096342153	Trim	Dichtung	Joint	1
14	532096342053	Rubber grommet	Kantenschutz	Anneau caoutchouc	1
15	532938703463	Lower steering support	Lagerung kompl.	Palier compl.	1
15.1	532938542073	Bearing	Lager	Palier	1
15.2	947323721002	Bushing 1920 KU	Büchse 1920 KU	Palier 1920 KU	1
16	947309203501	Hex screw M 6x16	Sechskantschraube M 6x16	Vis M 6x16	2
16.1	947311212516	Flat washer 6.6 zinc.	Scheibe 6.6 zinc.	Rondelle 6.6 zinc	2
16.2	947311129513	Self locking nut M 6	Sichermutter M 6	Ecrou M 6	2
17	532096342113	Trim	Dichtung	Joint	1
18	947532150550	Dashpanel 0-8048-285	Armaturenbrett 0-8048-285	Tableau 0-8048-285	1
19	947321841059	St.wheel bushing 0-1652-224	Abdeckung 0-1652-224	Manchon 0-1652-224	1
20	947309578503	Screw M 6x25 DIN 7991	Schraube M 6x25 DIN 7991	Vis M 6x25 DIN 7991	2
20.1	947311210502	Flat washer 6.4	Scheibe 6.4	Rondelle 6.4	2
20.2	947311129513	Self locking nut M 6	Sichermutter M 6	Ecrou M 6	2
21	947443821003	Steering wheel 0-8020-265	Lenkrad 0-8020-265	Volant 0-8020-265	1
22	947315238031	Spring pin 6x45	Spannstift 6x45	Goupille 6x45	1



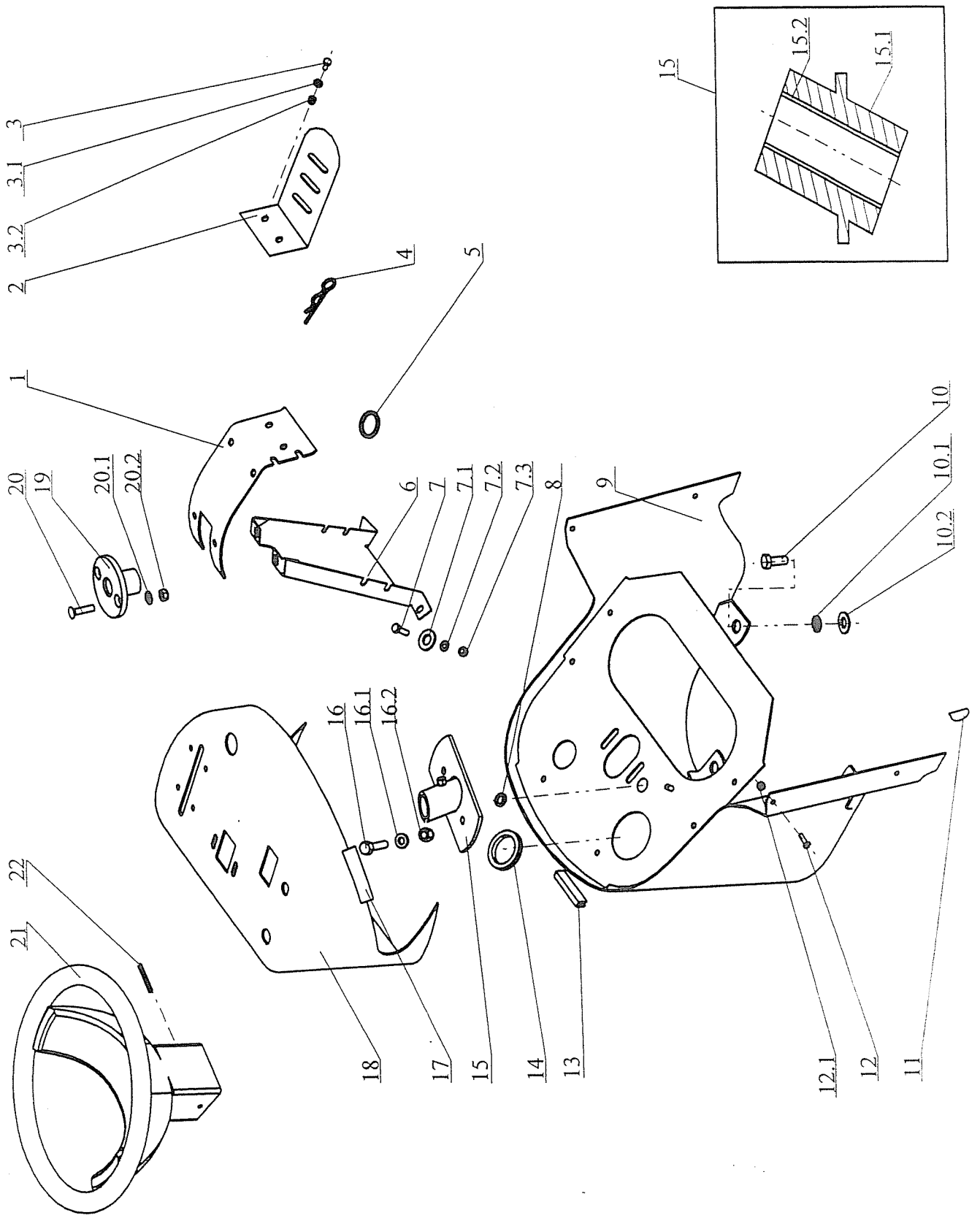

**SEAT ASSY  
SITZ  
SIÈGE**

12

2004

Nr.	REF.	DESCRIPTION	BEZEICHNUNG	DESIGNATION	QTY
1	947532150294	Seat	Sitz	Siege	1
2	532983362153	Bracket	Winkel	Equerre	1
3	532195202903	Spacer	Buchse	Entretoise	2
4	947315231194	Spring 0-9746-461	Druckfeder 0-9746-461	Ressort 0-9746-461	2
5	947722643019	Bushing 0-9421-424	Büchse 0-9421-424	Douille 0-9421-424	2
6	947309019519	Screw M 6x35 zinc	Sechskantschraube M 6x35 zinc	Vis hex M 6x35 zinc	2
6.1	947311212520	Washer 6	Scheibe 6	Rondelle 6	2
6.2	947311129513	Self locking nut M 6	Sicherungsmutter M 6	Ecrou M 6	2
7	947532150213	Locknut M 8x18 black	Arehgriff M 8x18 schwarz	Ecrou de retenue M 8x18 noir	2
7.1	947311213503	Flat washer 8.4 zinc.	Scheibe 8.4 zinc	Rondelle 8.4 zinc	2
8	947532150208	Cap 38 A/PVC black	Kappe 38 A/PVC schwarz	Couvercle 38 A/PVC noir	2
9	947315231124	Seat spring 0-9746-434	Druckfeder 0-9746-434	Ressort siege 0-9746-434	2
10	947309203504	Hex screw M 8x20	Sechskantschraube M 8x20	Vis hex M 8x20	2
10.1	947311212517	Washer 9 zinc.	Scheibe 9 zinc	Rondelle 9 zinc	2
10.2	947311210503	Falt washer 8.4	Scheibe 8.4	Rondelle 8.4	2
10.3	947311129501	Self locking nut M 8	Sicherungsmutter M 8	Ecrou de blocage M 8	2
11	947309599012	Screw 0-9016-427	Schraube 0-9016-427	Vis 0-9016-427	2
12	532018322413	Cover	Abdeckung	Cache	1
13	532113413453	Clip	Klemme	Attache	1
14	947309203504	Hex screw M 8x20	Sechskantschraube M 8x20	Vis hex M 8x20	2
14.1	947311214502	Washer 8	Scheibe 8	Rondelle 8	2
14.2	947311210503	Falt washer 8.4	Scheibe 8.4	Rondelle 8.4	2
14.3	947311219002	Washer 8x12x2 BN 739	Scheibe 8x12x2 BN 739	Rondelle 8x12x2 BN 739	2
15	532018472433	Seat support	Sitzplatte	Plaque siege	1
16	532113402403	Seat support bracket	Winkel	Support	2
17	947309203503	Hex screw M 8x16	Sechskantschraube M 8x16	Vis hex M 8x16	3
17.1	947311210503	Falt washer 8.4	Scheibe 8.4	Rondelle 8.4	6
17.2	947311214502	Washer 8	Scheibe 8	Rondelle 8	6
17.3	947311120502	Nut M 8	Sechskantmutter M 8	Ecrou M 8	6
18	947309203504	Hex screw M 8x20	Sechskantschraube M 8x20	Vis hex M 8x20	2

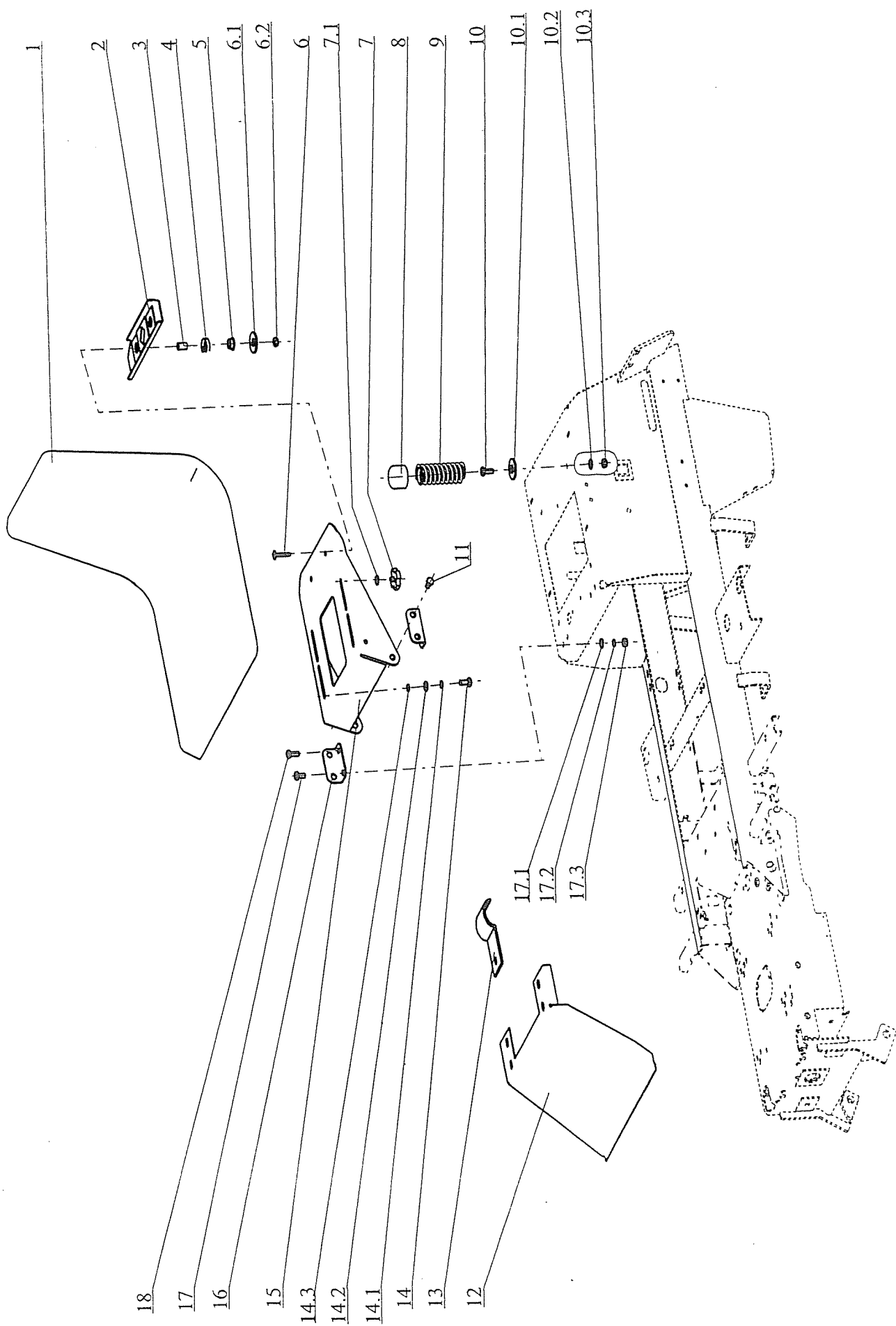

**BODY  
AUFBAUTEN  
CARROSSERIE**

13

2004

Nr.	REF.	DESCRIPTION	BEZEICHNUNG	DESIGNATION	QTY
19	947532150268	Hood assy 9-1849-272	Motor Haube 9-1849-272	Capot 9-1849-272	1
20	947321841051	Fender R 0-1847-312	Kotflügel 0-1847-312	Aile D 0-1847-312	1
21	947309578502	Carr. bolt M 5x20 DIN 799110.9	Schraube M 5x20 DIN 799110.9	Boulon M 5x20 DIN 799110.9	4
21.1	947311219501	Washer 5 SN213912 BN1276	Scheibe 5 SN213912 BN1276	Rondelle 5 SN213912 BN1276	4
21.2	947311212514	Flat washer 5.5 zinc.	Scheibe 5.5 zinc.	Rondelle 5.5 zinc.	4
21.3	947311214507	Spring washer 5	Scheibe 5	Rondelle 5	4
21.4	947311120506	Nut M 5	Sechskantmutter M 5	Ecrou M 5	4
22	947309203518	Hex screw M 4x16	Sechskantschraube M 4x16	Vis hex M 4x16	6
22.1	947311210506	Flat washer 4.3	Scheibe 4.3	Rondelle 4.3	6
22.2	947311212518	Flat washer 5.5 zinc.	Scheibe 5.5 zinc	Rondelle 5.5 zinc	6
22.3	947311129514	Self locking nut M 4	Sichermutter M 4	Ecrou M 4	6
23	947532150155	Fender L 0-1847-314	Kotflügellinks 0-1847-314	Aile G 0-1847-314	1
24	947309578502	Carr. bolt M 5x20 DIN 799110.9	Schraube M 5x20 DIN 799110.9	Boulon M 5x20 DIN 799110.9	4
24.1	947311219501	Washer 5 SN213912 BN1276	Scheibe 5 SN213912 BN1276	Rondelle 5 SN213912 BN1276	4
24.2	947311212514	Flat washer 5.5 zinc.	Scheibe 5.5 zinc.	Rondelle 5.5 zinc.	4
24.3	947311214507	Spring washer 5	Scheibe 5	Rondelle 5	4
24.4	947311120506	Nut M 5	Sechskantmutter M 5	Ecrou M 5	4
25	532018473563	Body bottom	Trittbrett	Plancher	1
26	947309019501	Screw M 8x20	Schraube M 8x20	Vis M 8x20	6
26.1	947311210503	Falt washer 8.4	Scheibe 8.4	Rondelle 8.4	6
26.2	947311214502	Washer 8	Scheibe 8	Rondelle 8	6
26.3	947311120502	Nut M 8	Sechskantmutter M 8	Ecrou M 8	6
27	947309203516	Screw M 10x25	Sechskantschraube M 10x25	Vis M 10x25	4
27.1	947311214503	Spring washer 10	Federscheibe 10	Rondelle 10	4
27.2	947311212521	Flat washer 11 zinc	Scheibe 11 zinc	Rondelle 11 zinc	4
28	532918452023	Bumper	Stossstange	Pare-chocs	1
29	947321841067	Cap	Blindflansch	Béquin	2
30	532013102143	Locking rod	Sicherstange	Gaule	1
31	947315231203	Spring 0-9746-472	Feder 0-9746-472	Resort 0-9746-472	1
32	532018473173	Heat cap	Luftleitblech	Capot	1
33	947309203537	Screw M6x18	Schraube M6x18	Vis M6x18	4
33.1	947311210502	Washer 6,4	Scheibe 6,4	Rondele 6,4	4
33.2	947311214501	Washer 6	Scheibe 6	Rondele 6	4
33.3	947311120501	Nut M6	Mutter M6	Ecrou M6	4

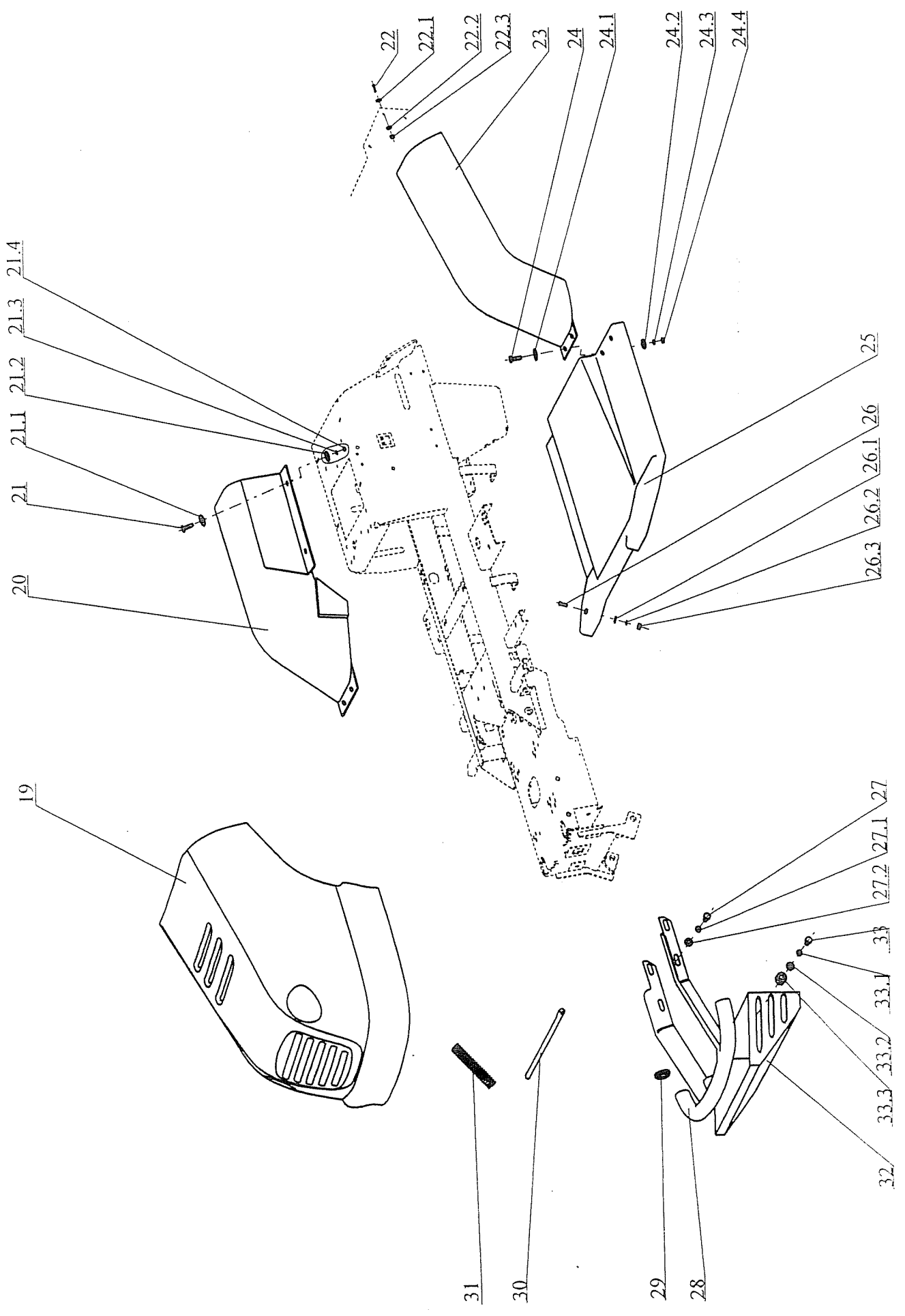

**ELECTRICAL SYSTEM  
ELEKTRO-KABELBAUM  
INSTALLATION ÉLECTRIQUE**

Nr.	REF.	DESCRIPTION	BEZEICHNUNG	DESIGNATION	QTY
1	947346211006	Akumulator 12V-24H	Batterie 12V-24H	Accumulateur 12V-24H	1
2	947309203502	Screw M 6x20	Schraube M 6x20	Vis M 6x20	2
2.1	947311210502	Flat washer 6.4	Scheibe 6.4	Rondelle 6.4	2
2.2	947311129513	Self locking nut M 6	Sichermutter M 6	Ecrou M 6	2
3	947532880041	Battery clamp	Sicherungsstange	Attache d'accumulateur	1
4	947232130001	Battery box 0-2765-201	Batteriewanne 0-2765-201	Coffre batterie 0-2765-201	1
5	947341271021	Battery cable - 9-8316-570	Minuskabel - 9-8316-570	Cable batteri - 9-8316-570	1
8	947311210501	Flat washer 5.3	Scheibe 5.3	Rondelle 5.3	1
9	947311129515	Locking nut M 5	Mutter M 5	Ecrou M 5	1
10	532113402583	Holder	Halter	Support	1
11	947341271006	Electrical lead 9-8316-553	Kabelbaum 9-8316-553	Faisceau élect 9-8316-553	1
12	947309203504	Hex screw M 8x20	Sechskantschraube M 8x20	Vis hex M 8x20	1
12.1	947311214502	Washer 8	Scheibe 8	Rondelle 8	1
12.2	947311210503	Falt washer 8.4	Scheibe 8.4	Rondelle 8.4	1
13	947532150125	Holder 0-8345-206	Halter 0-8345-206	Support 0-8345-206	1
14	947532150211	Clip WSBH-1-01	Klemme WSBH-1-01	Attache WSBH-1-01	1
15	947341271036	Wiring Harness 9-8316-578	Scheinwerferkabel 9-8316-578	Jeu d'ampoules 9-8316-578	1
16	947347224006	Light bulb 12V 10W K20	Glühlampe 12V/10W	Ampoule 12V/10W K20	2
17	947443953001	Lamp socket	Fassung	Manchon d'ampoule	2
18	947341271052	Protective diode	Diode	Diode de protection	1
19	947273121029	Bushing 22x4	Tülle 22x4	Douille 22x4	1
20	947341271089	Main wiring harn. 9-3819-475	Kable für Magnet 9-8319-475	Faisceau de conducteurs	1
21	947273121036	Bushing 15x2	Tülle 15x2	Douille 15x2	1
22	947273121036	Bushing 15x2	Tülle 15x2	Douille 15x2	1
23	947341271004	Electrical lead 9-8316-550	Kabelbaum 9-8316-550	Faisceau élect 9-8316-550	1
23.5	947341271005	Electrical lead 9-8316-552	Kabelbaum 9-8316-552	Faisceau élect 9-8316-552	1
24	947321841071	Cable clips	Kabelclips	Agrafe de cable	2
25	947358113026	Microswitch MK0-10-01	Schalter MK0-10-01	Interrupteur MK0-10-01	1
25.1	947311210505	Flat washer B 13	Scheibe B 13	Rondelle B 13	1
26	947358113026	Microswitch MK0-10-01	Schalter MK0-10-01	Interrupteur MK0-10-01	1
26.1	947311210505	Flat washer B 13	Scheibe B 13	Rondelle B 13	2
27	947000532079	Seat switch DELTA 6440-04	Sitzschalter DELTA 6440-04	Contacteur siege DELTA 6440-04	1
28	947443312021	Buzzer	Schnarre	Signalisation acoustique	1
29	947000532033	Solenoid 12V CLUM 94 255	Spule 12V CLUM 94 255	Solénoïde 12V CLUM 94 255	1
30	947309203501	Hex screw M 6x16	Sechskantschraube M 6x16	Vis M 6x16	2
30.1	947311210502	Flat washer 6.4	Scheibe 6.4	Rondelle 6.4	2
30.2	947311129513	Self locking nut M 6	Sichermutter M 6	Ecrou M 6	2
31	947309203548	Hex screw M 5x12	Sechskantschraube M 5x12	Vis M 5x12	2
31.1	947311210501	Flat washer 5.3	Scheibe 5.3	Rondelle 5.3	4
31.2	947311129515	Self locking nut M5	Sichermutter M5	Ecrou M5	2
32	947443861005	3 position key switch INDAK	Schalter INDAK 3Y463A	Contact à clef INDAK 3Y463A	1
32.1	532092207513	Flat washer	Scheibe	Rondelle	1
33	947345329013	Switch 1932.3112	Schalter 1932.3112	Interrupteur lames 1932.3112	2
34	947000532039	Blade clutch switch G 671	Schalter Mahwerk G 671	Interrupteur lames G 671	1
35	947443811004	Relay	Relay	Relais	1
36	947309203548	Hex screw M 5x12	Sechskantschraube M 5x12	Vis M 5x12	1
36.1	947311210501	Washer 5,3	Scheibe 5,3	Rondelle 5,3	2
36.2	947311129515	Nut M5	Mutter M5	Ecrou M5	1
37	947443433002	Hour meters QUARTZ	Stundenzähler QUARTZ	Compter d'heures de moteur	1
38	947321841071	Cable clips	Kabelclips	Agrafe de cable	4
39	947532150055	Cap "KAPSTO" GPN 910-D53	Kappe "KAPSTO" GPN 910-D53	Capuchon "KAPSTO" GPN 910-D53	1
40	947532150207	Clip RT 360-150	Klemme RT 360-150	Attache RT 360-150	1
41	947311219498	Washer 12x18x1 DIN 988	Scheibe 12x18x1 DIN 988	Rondelle 12x18x1 DIN 988	1
42	947273125006	Rubber boot	Mantel	Manchon caoutchouc	2
43	532085427153	Cap	Schalterkappe	Capuchon	1
44	947273121035	Bushing 8x1	Tülle 8x1	Douille 8x1	1
45	947311691001	Rivet 2,9x8	Niete 2,9x8	Rivet 2,9x8	1
46	532085427173	Cap	Schalterkappe	Capuchon	1
49	947532150211	Clip WSBH-1-01	Klemme WSBH-1-01	Attache WSBH-1-01	2
50	947532150211	Clip WSBH-1-01	Klemme WSBH-1-01	Attache WSBH-1-01	1
51	947532150207	Clip RT 360-150	Klemme RT 360-150	Attache RT 360-150	4
52	947286134002	Flexible tube	Flexibler Schlauch	Flexible tube	1

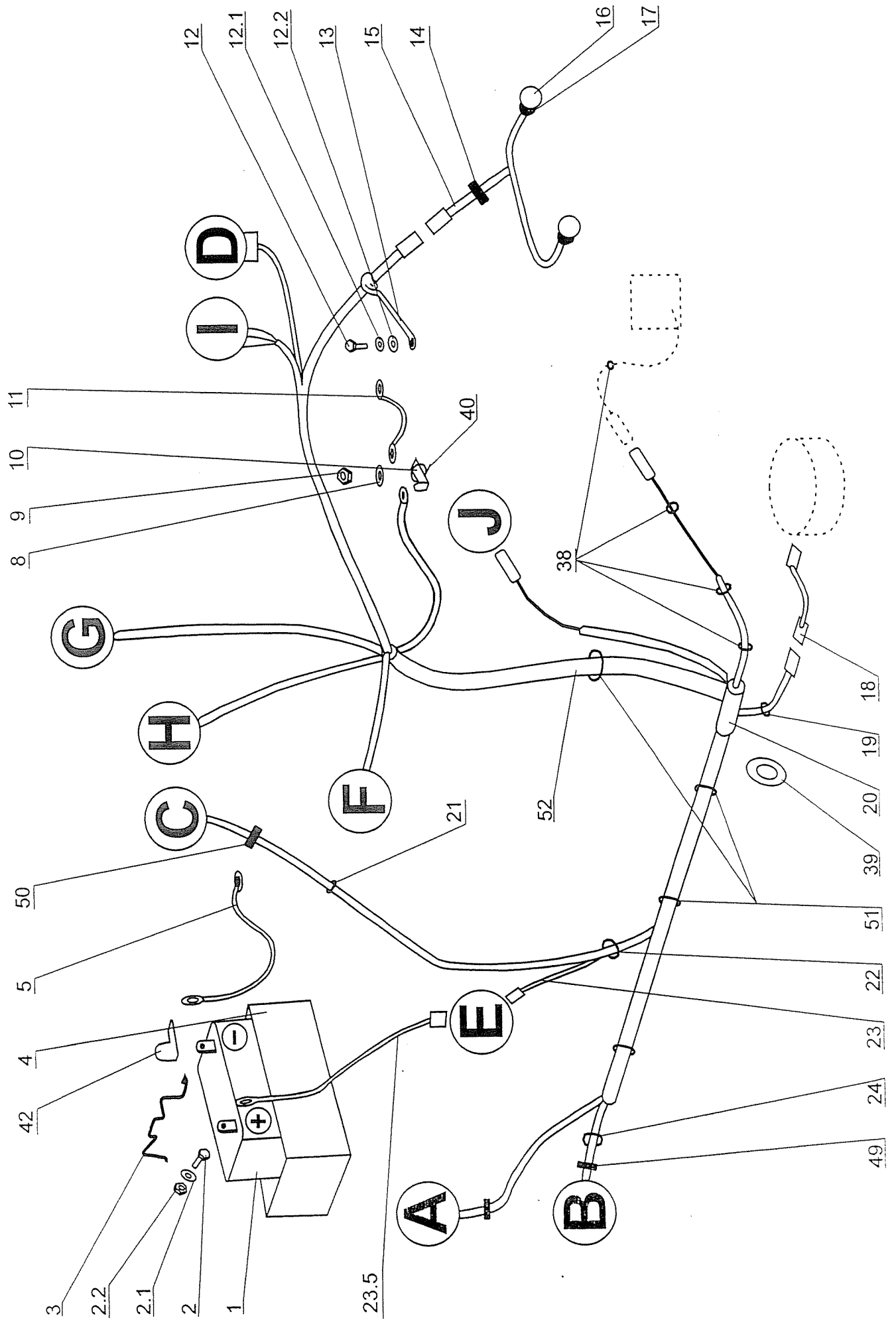

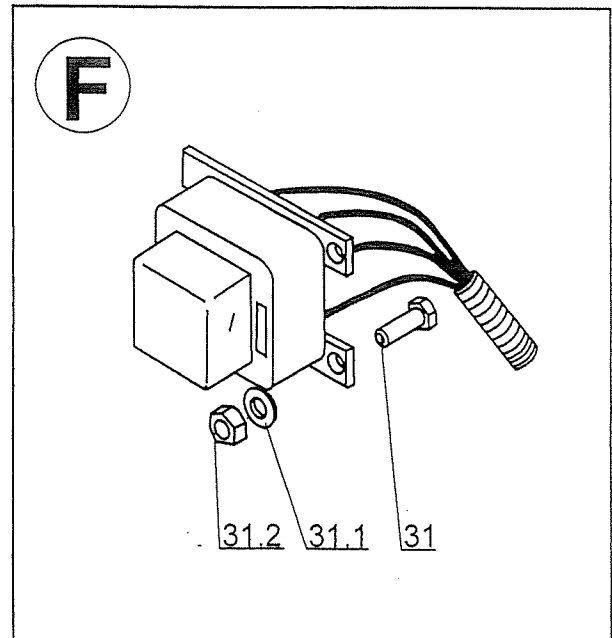
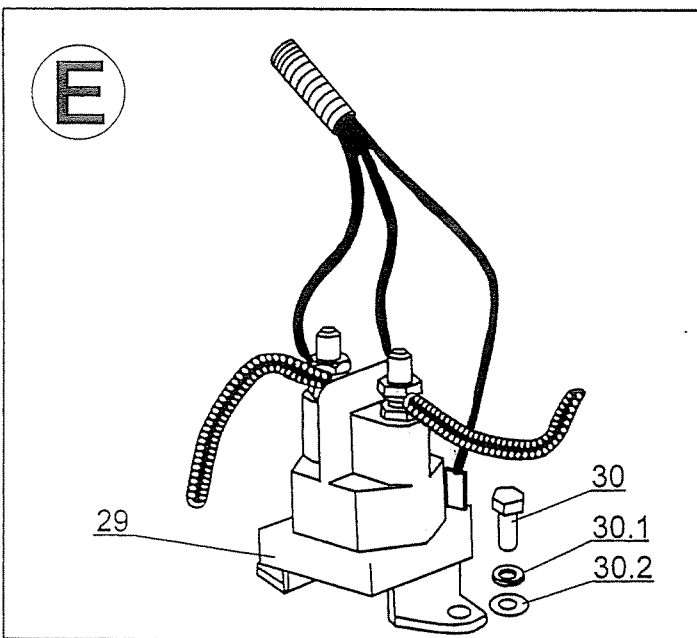
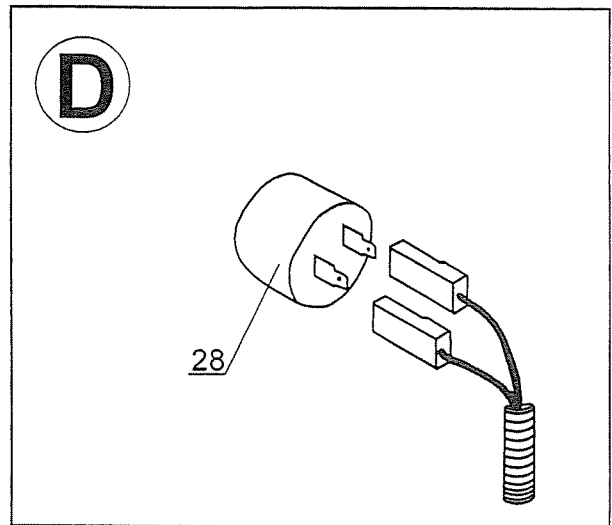
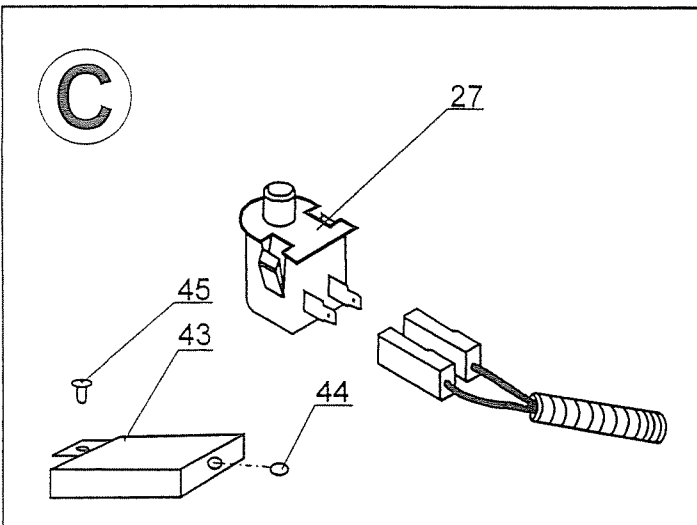
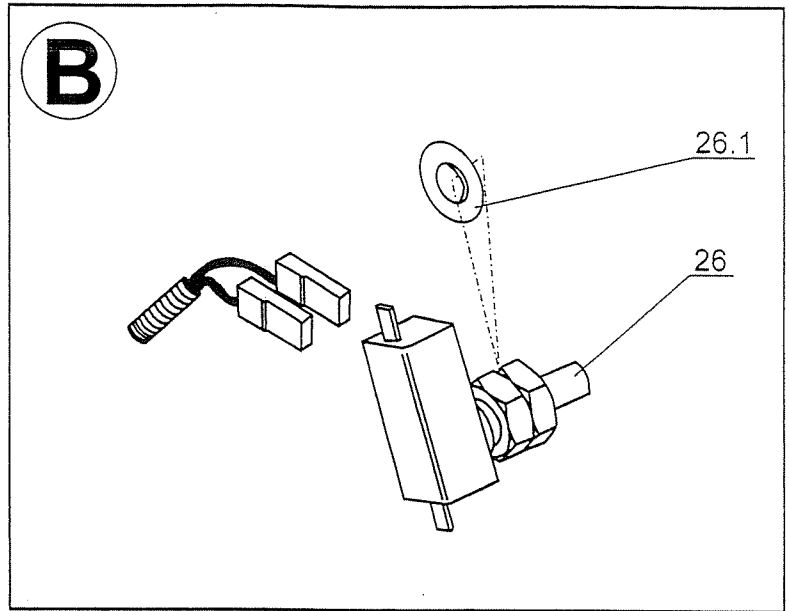
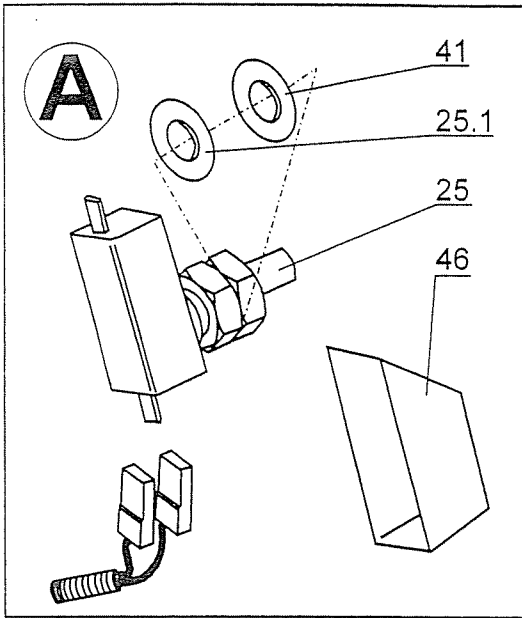



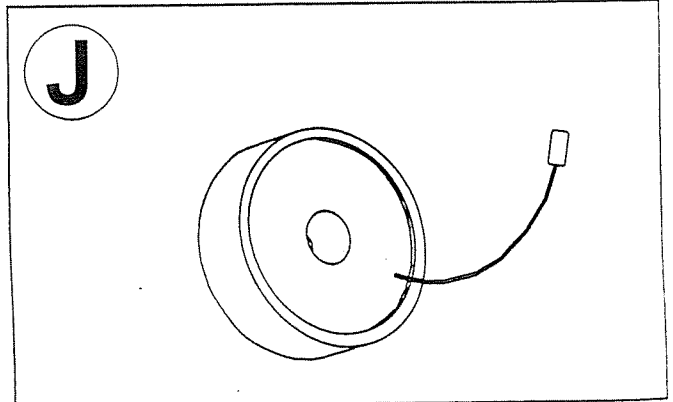
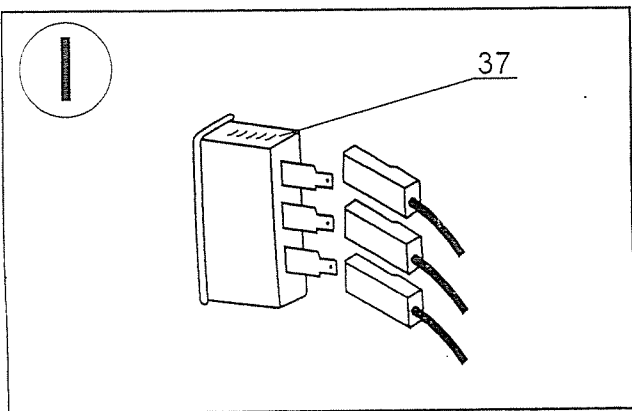
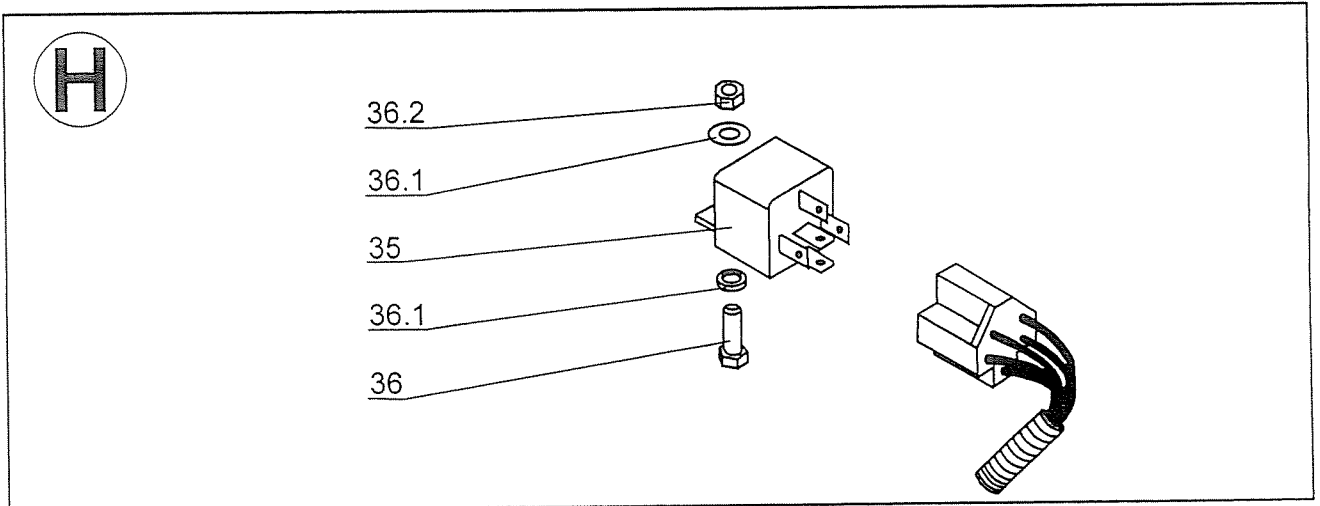
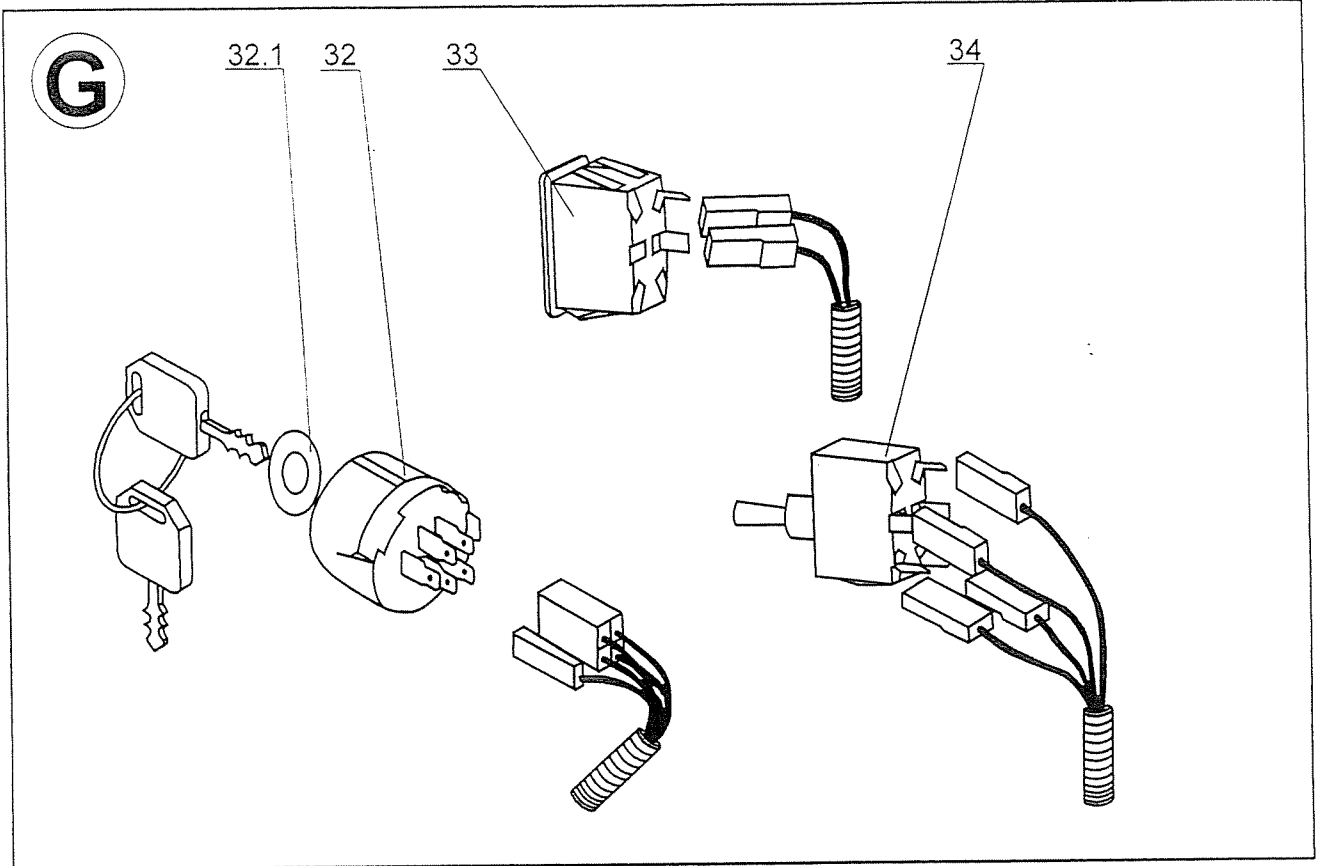

**LABELS  
AUFKLEBER  
ETIQUETTES**

15

2004

Nr.	REF.	DESCRIPTION	BEZEICHNUNG	DESIGNATION	QTY
1	947283292126	Decal arrow 0-8730-509	Etikette 0-8730-509	Étiquette 0-8730-509	2
2	947283292240	Users inform. label 0-8732-371	Etikette 0-8732-371	Etiquette 0-8732-371	1
3	947283292159	Decal 0-8732-251	Etikette 0-8732-251	Etiquette 0-8732-251	1
4	947283292251	Decal 0-8732-370	Etikette 0-8732-370	Etiquette 0-8732-370	1
5	947283292249	Decal 0-8732-368	Etikette 0-8732-368	Etiquette 0-8732-368	1
6	947283292444	Decal 0-8732-565	Etikette 0-8732-565	Etiquette 0-8732-565	1
7	947283292380	Decal 0-8732-493	Etikette 0-8732-493	Etiquette 0-8732-493	1
8	947283292384	Label 0-8732-500	Etikette 0-8732-500	Etiquette 0-8732-500	3
9	947283292274	Label 0-8732-361	Etikette 0-8732-361	Etiquette 0-8732-361	1
10	947283292223	Self-adhes.label,safety instru	Etikette Sicherheitinstruktion	Étiquette instructions de sécu	1
11	947283292327	Label 0-8732-444	Etikette 0-8732-444	Etiquette 0-8732-444	1
12	947283292437	Label 0-8732-559 bluster	Etikette 0-8732-559 Geräusch	Étiquette 0-8732-559 boucan	1
13	947283292121	Self-adhes.label mowing safety	Etikette sich. mäh.	Étiquette	1
14	947283292243	Safety label 0-8732-362	Etikette 0-8732-362	Etiquette 0-8732-362	1
15	947283292245	Label of lifting 0-8732-364	Etikette 0-8732-364	Etiquette 0-8732-364	1
16	947283292246	Label of lifting 0-8732-365	Etikette 0-8732-365	Etiquette 0-8732-365	1
17	947283292272	Label 0-8732-359	Etikette 0-8732-359	Etiquette 0-8732-359	1
18	947283292192	Hydro locking decal 0-8732-311	Etikette 0-8732-311 Hydro 0-1	Étiquette 0-8732-311 hydro 0-1	1
19	947283292230	Label 0-8732-358	Etikette 0-8732-358	Étiquette 0-8732-358	1
20	947283292302	Self-adhes.label 0-8732-395	Etikette 0-8732-395	Étiquette 0-8732-395	1
21	947283292273	Label 0-8732-360	Etikette 0-8732-360	Etiquette 0-8732-360	1
22	947283292432	Self-adhes.label 0-8732-536	Etikette 0-8732-536	Etiquette 0-8732-536	1

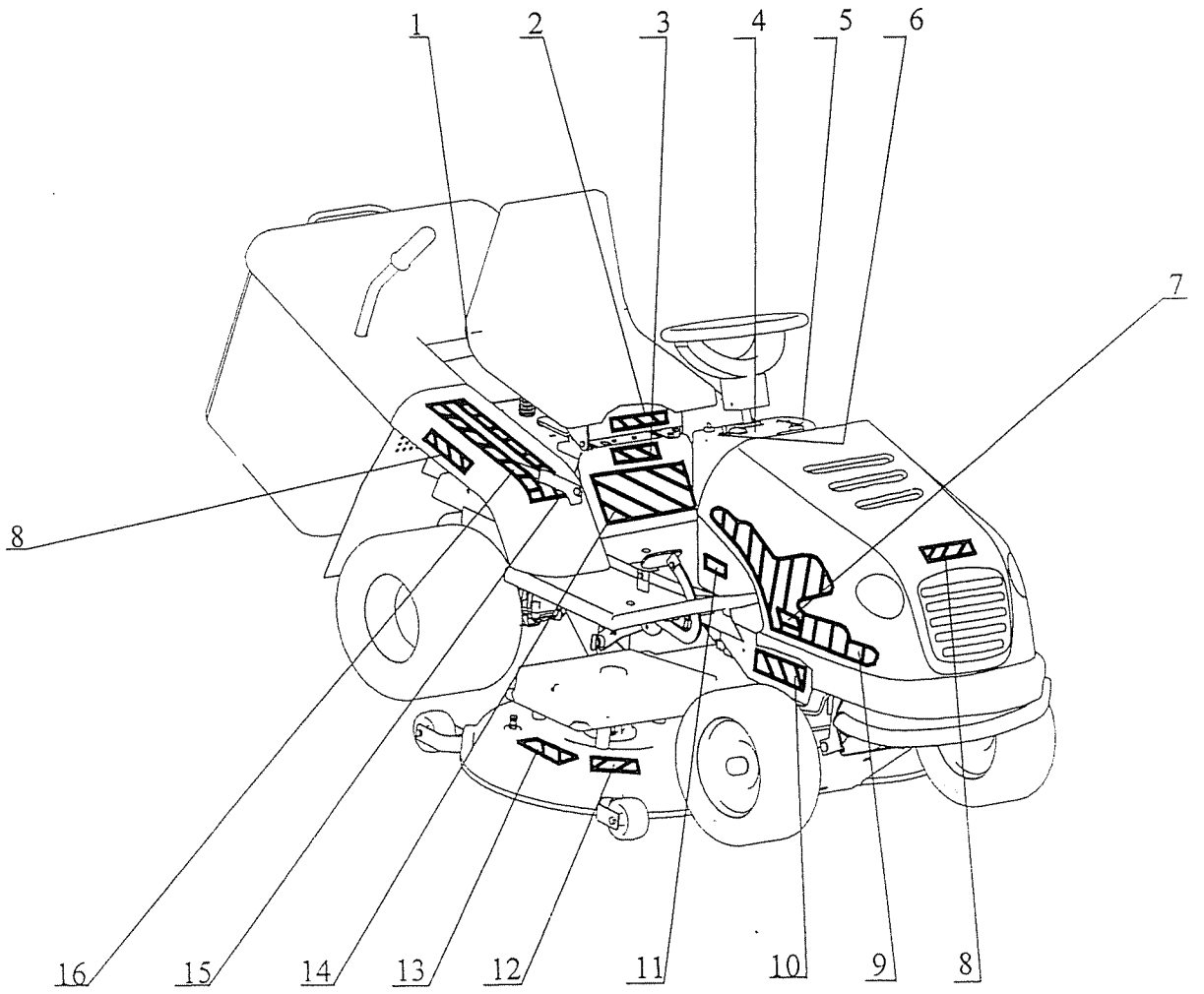
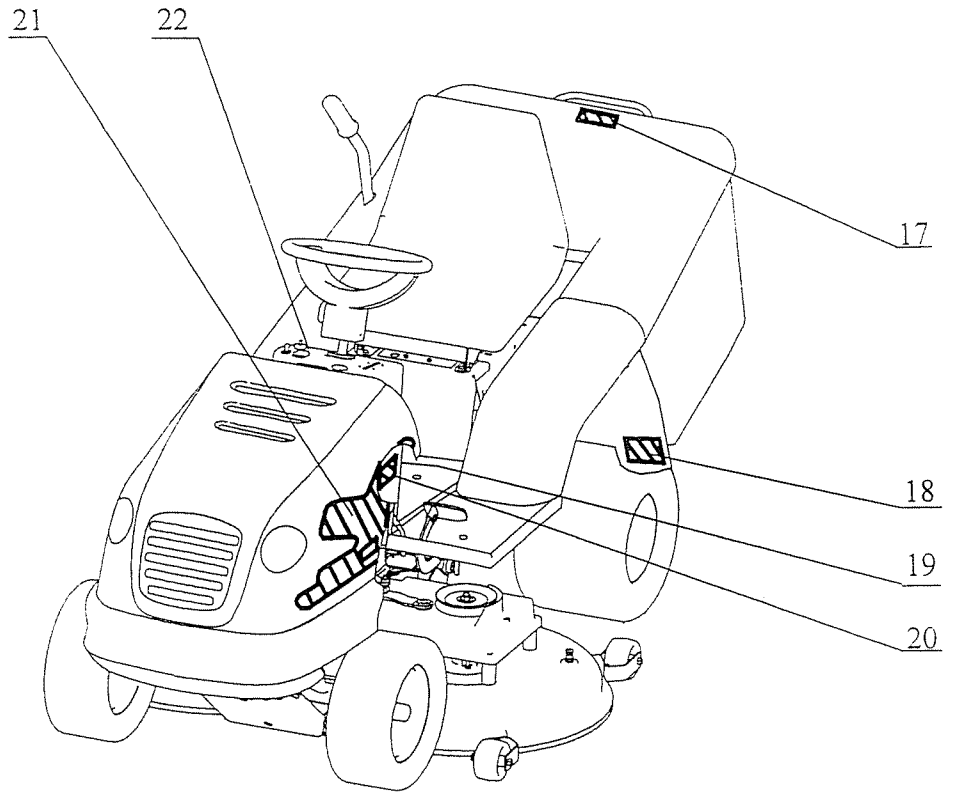

---

The manufacturer continuously improves the products on the basis of experience gained in the course of operation and up-to-date knowledge. He reserves the right of modifying the product as well as the respective documentation. Your tractor may be different from the description in the parts catalogue. However this does not effect essential tractor features or the operation.

**NOTE:**

Engine, electro-magnetic clutch and transmission components are not included.  
Parts for these items must be ordered from the respective distributors.

---

Der Hersteller ist bemüht das Gerät laufend zu verbessern und im Zuge der technischen Entwicklung Anpassungen vorzunehmen. Er behält sich das Recht auf technische Veränderungen der Maschine und Anpassung der Dokumentation vor.  
Die Ausführung Ihres Gerätes kann daher von dieser Dokumentation abweichen. Essentielle Funktionen oder die Handhabung des Gerätes sind davon nicht betroffen.

**ANMERKUNG:**

Motor, elektromagnetische Kupplung und Getriebe sind nicht in Einzelteilen aufgeführt.  
Ersatzteile für diese Komponenten müssen beim zuständigen Fachhändler bestellt werden.

---

Le fabricant s'efforce d'améliorer en permanence ses produits ou d'y adapter les nouvelles technologies en vigueur. Il se réserve en conséquence le droit de modifier le produit à tout moment ainsi que la documentation qui s'y rapporte. Il se peut donc que votre tracteur présente quelques différences avec cette documentation. En aucun cas, cela ne doit altérer les fonctions essentielles et l'utilisation de la machine.

**N.B.:**

Le Moteur, l'embrayage électromagnétique et la transmission ne sont pas détaillés.  
Les pièces pour ces composants doivent être commandées chez le distributeur respectif.

---







